

SmartLam GL18 Design Guide

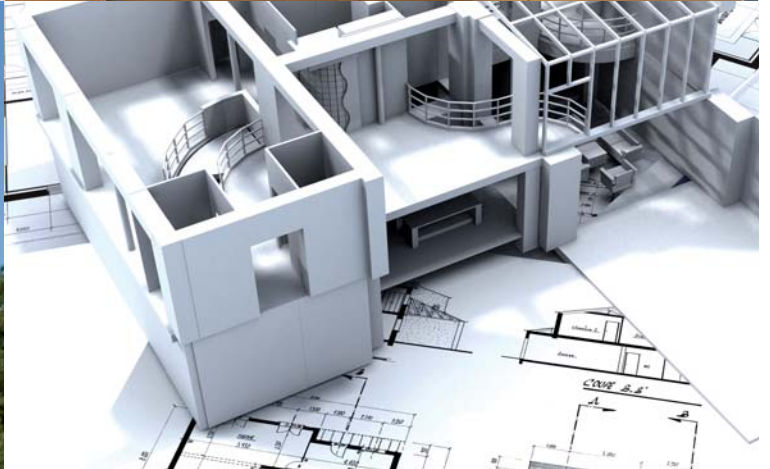

SCOPE OF THIS PUBLICATION

This Design Guide and Load Tables assist in the selection of SmartLam GL18 beams for most of the common structural arrangements met in domestic construction.

Methods of developing lateral restraint and providing adequate support, adequate anchorage against wind uplift, and overall structural stability are outside the scope of this publication.

Information on the above matters can be obtained from AS 1684 Residential timber-framed construction or from a structural engineer experienced in timber construction.

Tilling Timber Pty Ltd have structural engineers within the SmartFrame Design Centre who can be contacted for advice on matters concerning the use of its SmartFrame engineered timber products in timber construction via the SmartData Customer HelpLine on 1300 668 690 or e-mail at smartdata@tilling.com

SUBSTITUTION OF OTHER PRODUCTS

All load tables in this document are designed using the characteristic properties of GL18 defined in table 7.1 of AS 1720.1, manufactured to AS/NZS 1328 by quality producers and distributed by Tilling Timber Pty Ltd.

COPYRIGHT

Copyright of this publication remains the property of Tilling Timber Pty Ltd, and reproduction of the whole or part of this publication without written permission from Tilling Timber Pty Ltd is prohibited.

CERTIFICATION

As a professional engineer, qualified and experienced in timber engineering, I certify that the use of the SmartLam GL18 members as shown in these tables, and installed in accordance with the provisions of this Design Guide, complies to the Building Code of Australia. These span tables have been prepared in accordance with standard engineering principles, the relevant test reports and Australian standards, ie:

- AS 1684.1 Residential timber-framed construction
- AS 1170.1 Structural design actions – permanent imposed and other actions
- AS 1720.1 Timber structures - design methods
- AS 4055 Wind loads for houses
- AS/NZS 4063 Characterisation of structural timber
- AS/NZS 1328 Glue laminated structural timber - performance requirements and minimum production requirements.
- GLTAA Unified design criteria



CRAIG KAY PEng, RPEQ-5100, EC-1961, BPB0730, CC56335 C NPER
National Product Manager - EWP



SmartFrame Product Warranty*

Tilling Timber warrants that its SmartFrame Engineered Wood products will be free from manufacturing defects in workmanship and material.

In addition, provided the product is correctly installed and used, Tilling Timber warrants the adequacy of its design for the normal and expected life of the structure.

This warranty is backed by the full resources of Tilling Timber and by underwritten product liability insurance.

Tilling Timber Pty Ltd
Head Office and Manufacturing
31-45 Orchard Street
Kilsyth Vic 3137
Ph: +61 (0)3 9725 0222 Fax: +61 (0)3 9725 6569
Email: smartdata@tilling.com.au

TABLE OF CONTENTS

INTRODUCTION	1
TECHNICAL DATA	
- GLTAA deflection limits	1
- Design loads	2
- Duration of load/service class	2
ENGINEERING PROPERTIES	
- Characteristic strengths	2
- Capacity reduction factor	2
- beam properties	3
- Pre-camber based upon span	4
ORDERING SmartLam GL18	4
PROTECTION AND HANDLING	4
INSTALLATION	
- Preparatory work	4
- Deflection	4
- Verticality	4
- Notches	4
- Holes for services	4
- Birdsmouthing	5
- Eaves overhang	5
MULTIPLE SmartLam GL18 SECTION BEAMS	
- Top loaded beams	6
- Side loaded beams	6
SmartLam DESIGN/EFFECTIVE SPAN	7
DURABILITY AND WEATHER EXPOSURE RECOMMENDATIONS	8
PROTECTION METHODS	
- During construction	8
- Exterior applications	8
- Design and construction detailing tips	8
PAINTING LOSP TREATED SmartLam BEAMS	9
FIRE RATINGS (RESISTANCE)	9
CHECKING IN SmartLam GLULAM	9
QUALITY ASSURANCE	10
SAFETY PRECAUTIONS	10
INDEX OF CHARTS AND SPAN TABLES	11

INTRODUCTION

THE PRODUCT

SmartLam GL18 beams are manufactured to AS/NZS 1328 by quality Glulam manufacturers. SmartLam GL18 Glulam beams are engineered timber products with high strength, dimensional stability, great load carrying capacity, superior fire resistance, and are manufactured from select quality Pine timber.

All timber used for laminating is carefully selected from production and graded according to specification. After trimming to the desired size, all stock is kiln dried to 12% average moisture content, to ensure efficient bonding in the gluing operations. The laminations are finger jointed by machine, with glue being cured by cold press system and controlled temperature.



SmartLam GL18 are available in A, B & C appearance Grades and are pre-cambered to a radius of 600 metres. **Uncambered SmartLam GL18 beams are available to order.**

BENEFITS OF SmartLam GL18

COST EFFECTIVENESS - SmartLam GL18 beams high strength to weight ratio allows you to design for maximum loads over large spans with the smallest possible end sections.

PRODUCT QUALITY - All SmartLam GL18 beams are manufactured in accordance with AS 1328 Glue Laminated Structural Timber and the Glued Laminated Timber Association (GLTAA) Industry standard GLTAA-4-91.

FIRE SAFETY - Extensive fire test data shows that large end section timber performs well in fire situations due to the formation of a protective layer of char which usually occurs at a temperature around 250° C. This charred area inhibits the effects of the fire on the inner portion of the timber component, hence it maintains structural load support for measurable periods of time as the fire progresses.

Conversely, steel loses its strength rapidly as the temperature is raised. At about 550°C, it has lost about 50% of its original bending strength, and by 750°C it has lost 90%. Timber does not lose strength in the same way, with the loss of section size through charring the major reason for any strength reduction.

FAST EASY ERECTION - Timber is a user friendly building material, requiring no special tools other than those a normal builder would use, and with SmartLam GL18 beams, installation is fast, easy and efficient.

ENVIRONMENTAL RESPONSIBILITY - SmartLam GL18 beams are made from timber from sustainable managed forests, a natural resource that is friendly to the environment.

LOW MAINTENANCE - In most applications, SmartLam GL18 beams will require little or no maintenance other than that which you would ordinarily carry out to any structural material.

NATURAL BEAUTY - The natural beauty of timber is desired and highly appropriate in many architectural applications. Appearance Grade A & B SmartLam GL18 beams allow you to build timber's natural warmth and beauty into your designs.

TECHNICAL DATA

DESIGN CRITERIA

Deflection limits

The deflection limits applied in these tables are as stated in Table 1 and are in accordance the Glued Laminated Timber Association of Australia (GLTAA) Unified Design Criteria

Table 1: Deflection limits

MEMBER	LONG TERM		SHORT TERM	
	$J_2 \times D.L$	$J_2 \times (DL+0.6 \text{ kPa})$	L.L	SERVICEABILITY W.L
BEARERS (floor loads only)		$\frac{SPAN}{300}$ or 15 mm	$\frac{SPAN}{360}$ or 18 mm	
BEARERS (with roof loads)		$\frac{SPAN}{300}$ or 15 mm	$\frac{SPAN}{360}$ or 18 mm	$\frac{SPAN}{250}$ or 9 mm
JOISTS		$\frac{SPAN}{300}$ or 15 mm	$\frac{SPAN}{360}$ or 9 mm	
LINTELS (with roof loads only)	$\frac{SPAN}{300}$ or 9 mm		$\frac{SPAN}{250}$ or 9 mm	$\frac{SPAN}{250}$ or 9 mm
LINTELS (with roof and floor)		$\frac{SPAN}{300}$ or 10 mm	$\frac{SPAN}{250}$ or 9 mm	$\frac{SPAN}{250}$ or 9 mm
STRUTTING, HANGING, COUNTER BEAMS	$\frac{SPAN}{300}$ or 15 mm		$\frac{SPAN}{270}$ or 15 mm	$\frac{SPAN}{150}$
HANGING/STRUTTING, COUNTER/STRUTTING	$\frac{SPAN}{300}$ or 12 mm		$\frac{SPAN}{300}$ or 12 mm	$\frac{SPAN}{150}$
ROOF BEAMS, RAFTERS, HIPS	$\frac{SPAN}{300}$ or 20 mm		$\frac{SPAN}{250}$	$\frac{SPAN}{150}$
PATIO & VERANDAH BEAMS	$\frac{SPAN}{400}$ or 10 mm		$\frac{SPAN}{250}$ or 12 mm	$\frac{SPAN}{200}$

For Long Term - Camber may in some circumstances be added to Deflection limits
 WHERE: DL = DEAD LOAD, LL = LIVE LOAD, WL = WIND LOAD, J_2 = FACTOR FOR DURATION OF LOAD

Design loads

Table 4

Dead loads are:

Sheet roof without ceiling	20 kg/m ²
Sheet roof with ceiling	40 kg/m ²
Fibro roof with ceiling	60 kg/m ²
Tiled roof without ceiling	60 kg/m ²
Tiled roof with ceiling	75 kg/m ²
Timber floor with ceiling under	40 kg/m ²

Live loads are:

Roof (Non trafficable) = 0.25 kPa minimum (1.8/area + 0.12) kPa or 0.25 kPa maximum.	
Floor loads (domestic)	1.5 kPa
External - greater than 1 m above ground	2.0 kPa
- Less than 1 m above ground	1.5 kPa

Duration of load/service class

Table 5

Duration of Load Factor (J_2)

Duration	Service class / exposure classification		
	1, 2	3	Severe/Adverse
Short Term <= 1 Day	1.0	1.0	1.0
Long Term > 12 months	1.5	2.0	3.0*

Notes:

- Any beams to be used in service class 3 are outside the scope of these span tables, therefore specialist design advice should be sought from an engineer. In general, the size of this beam can conservatively be obtained by the following method:
 - Obtain the beam size for service class 1 & 2
 - Obtain the EI_x from the "Section Properties" table for this beam
 - Obtain from the "Section Properties" table a beam size with an $EI_x \geq 2/1.5 \times EI_x$ of the original beam
 - Follow the recommendations of the GLTAA Technical Data sheet No 2: Glulam in weather exposed applications"

* indicates severe / adverse conditions which are beyond the scope of these span tables and specialist design advice from a engineer should be sought.
- Service Classes 1,2 & 3 are defined in AS1328

ENGINEERING PROPERTIES

Table 6

Glulam Grade	Characteristic Strengths (MPa)				Elastic Moduli (MPa)	
	Bending (F'_b)	Tension parallel to grain (F'_t)	Shear in beam (F'_s)	Compression parallel to grain (F'_c)	Short duration modulus of elasticity parallel to the grain (E)	Short duration modulus of rigidity for beams (G)
SmartLam GL18	45	25	5.0	45	18500	1230

CAPACITY FACTORS (Φ) FOR USE WITH SmartLam GL18:

The capacity factor Φ for calculating the design capacity for a structural member depends upon the type of structural material and the application of the member as described in table 2.1 of AS 1720.1. SmartLam GL18 used as a structural element in structures presenting a low degree of hazard to life and other property in case of failure (includes houses) has a capacity factor Φ of 0.95. For other structural applications including beams within houses that support an area greater than 25 m², the values of Φ should be obtained from Table 2.1 of AS 1720.1. All the tables within this document have been prepared with the value of $\Phi = 0.95$

OTHER PROPERTIES :

Strength group	SD4
Joint group	JD3
Density	~ 650 kg/m ³
Service class	2 (EMC not to exceed 20% in service)

DIMENSIONAL TOLERANCES:

Height or	<100	+2 mm, -2 mm
Width	100<300	+3 mm, -3 mm
	300<600	+4 mm, -4 mm
	>600	+6 mm, -6 mm

ADHESIVE:

Waterproof resins to include Resorcinol, Phenol/resorcinol' and polyphenolics

CURING:

Cold press system and controlled temperature

LENGTH:

Stock beams up to 12 m

PRE-CAMBER:

All stock SmartLam GL18 beams are supplied with a built in camber of a radius of 600 metres. SmartLam GL18 beams can be ordered either straight or with or a user specified pre-camber. (see ordering SmartLam GL18)

BEAM PROPERTIES

Table 6 - Section Properties for SmartLam GL18 - Glued laminated beams

SmartLam GL18 beam properties

Nominal size DxB mm	Beam mass kg/m	Nominal section area 10 ³ mm ²	Major axis			Minor Axis	
			Z _{xx} 10 ³ mm ²	I _{xx} 10 ⁹ mm ⁴	EI _{xx} 10 ⁹ Nmm ²	Z _{yy} 10 ³ mm ²	I _{yy} 10 ⁹ mm ⁴
150 x 65	6.3	9.8	244	18	338	105.6	3.4
180 x 65	7.6	11.7	351	32	584	126.8	4.1
210 x 65	8.9	13.7	478	50	928	147.9	4.8
240 x 65	10.1	15.6	624	75	1385	169.0	5.5
270 x 65	11.4	17.6	790	107	1972	190.1	6.2
300 x 65	12.7	19.5	975	146	2706	211.3	6.9
330 x 65	13.9	21.5	1180	195	3601	232.4	7.6
360 x 65	15.2	23.4	1404	253	4675	253.5	8.2
390 x 65	16.5	25.4	1648	321	5944	274.6	8.9
420 x 65	17.7	27.3	1911	401	7424	295.8	9.6
450 x 65	19.0	29.3	2194	494	9131	316.9	10.3
480 x 65	20.3	31.2	2496	599	11082	338.0	11.0
510 x 65	21.5	33.2	2818	719	13293	359.1	11.7
540 x 65	22.8	35.1	3159	853	15779	380.3	12.4
570 x 65	24.1	37.1	3520	1003	18558	401.4	13.0
600 x 65	25.4	39.0	3900	1170	21645	422.5	13.7
150 x 85	8.3	12.8	319	24	442	180.6	7.7
180 x 85	9.9	15.3	459	41	764	216.8	9.2
210 x 85	11.6	17.9	625	66	1214	252.9	10.7
240 x 85	13.3	20.4	816	98	1812	289.0	12.3
270 x 85	14.9	23.0	1033	139	2579	325.1	13.8
300 x 85	16.6	25.5	1275	191	3538	361.3	15.4
330 x 85	18.2	28.1	1543	255	4709	397.4	16.9
360 x 85	19.9	30.6	1836	330	6114	433.5	18.4
390 x 85	21.5	33.2	2155	420	7773	469.6	20.0
420 x 85	23.2	35.7	2499	525	9709	505.8	21.5
450 x 85	24.9	38.3	2869	645	11941	541.9	23.0
480 x 85	26.5	40.8	3264	783	14492	578.0	24.6
510 x 85	28.2	43.4	3685	940	17383	614.1	26.1
540 x 85	29.8	45.9	4131	1115	20634	650.3	27.6
570 x 85	31.5	48.5	4603	1312	24268	686.4	29.2
600 x 85	33.2	51.0	5100	1530	28305	722.5	30.7
150 x 110	10.7	16.5	413	31	572	302.5	16.6
180 x 110	12.9	19.8	594	53	989	363.0	20.0
210 x 110	15.0	23.1	809	85	1571	423.5	23.3
240 x 110	17.2	26.4	1056	127	2344	484.0	26.6
270 x 110	19.3	29.7	1337	180	3338	544.5	29.9
300 x 110	21.5	33.0	1650	248	4579	605.0	33.3
330 x 110	23.6	36.3	1997	329	6094	665.5	36.6
360 x 110	25.7	39.6	2376	428	7912	726.0	39.9
390 x 110	27.9	42.9	2789	544	10060	786.5	43.3
420 x 110	30.0	46.2	3234	679	12564	847.0	46.6
450 x 110	32.2	49.5	3713	835	15453	907.5	49.9
480 x 110	34.3	52.8	4224	1014	18755	968.0	53.2
510 x 110	36.5	56.1	4769	1216	22495	1028.5	56.6
540 x 110	38.6	59.4	5346	1443	26703	1089.0	59.9
570 x 110	40.8	62.7	5957	1698	31406	1149.5	63.2
600 x 110	42.9	66.0	6600	1980	36630	1210.0	66.6

Pre - Camber in mm based upon camber radius of 600 m.

Table 8

CAMBER BASED UPON 600 m RADIUS

Beam length (m)	Camber (mm)	Beam length (m)	Camber (mm)	Beam length (m)	Camber (mm)
3.3	2.2	6.3	8.3	9.3	18.0
3.6	2.7	6.6	9.1	9.6	19.2
3.9	3.1	6.9	9.9	9.9	20.4
4.2	3.7	7.2	10.8	10.2	21.6
4.5	4.2	7.5	11.7	10.5	23.0
4.8	4.8	7.8	12.7	10.8	24.3
5.1	5.4	8.1	13.7	11.1	25.7
5.4	6.0	8.4	14.7	11.4	27.0
5.7	6.8	8.7	15.7	11.7	29.0
6.0	7.5	9.0	16.9	12.0	30.0

ORDERING SmartLam GL18

SmartLam GL18 glulam can be purchased with or without camber and in different appearance grades.

AS/NZS 1328.2 defines 3 appearance grades:

- Appearance Grade A - Sanded with any voids filled - intended for applications where appearance is important and clear or painted finishes are used
- Appearance Grade B - intended for applications where appearance is important but where a planed finish is acceptable
- Appearance Grade C - intended for applications where appearance is unimportant

SmartLam GL18C B grade

Appearance Grade

"C" indicates pre-cambered
"S" indicates no pre-camber (straight)

Stock SmartLam GL18 will be supplied pre-cambered in B grade finish unless otherwise specifically requested.

PROTECTION AND HANDLING

All beams are wrapped at the factory to protect against weather and handling during storage and transport. Care should be taken during delivery to avoid marking and to avoid damage. Unloading of trucks should be done by hand or with a crane, do not drop or dump members. During unloading with lifting equipment, use fabric or plastic belts or other slings which will not mark the wood. If chains or cables are used, provide protective blocking or padding. Guard against soiling, dirt, footprints, abrasions, or injury to sharp edges or corners.

INSTALLATION

PREPARATORY WORK

Carefully unload and handle the laminated members at job site to prevent surface marking and damage. If laminated timber is to be stored before erection, place it on blocks well off the ground with individual members separated by strips so that air may circulate around all four sides. The top and the sides of storage pile shall be covered with moisture resistant covering. Wrapping shall be left intact, but individual wrappings shall be slit or punctured on the lower side to permit the drainage of water that may have accumulated. Before erection, the assembly should be checked for any damage from water or handling, prescribed camber, and accuracy of anchorage connections.

Laminated beams can be nailed into place in the same way as solid timber beams. Alternatively, a range of plates are available for end fixing. For larger beams, special purpose, engineer designed end fixing should be used.

DEFLECTION

All structural members deflect downwards when dead loads are applied, and therefore it is important to allow for this deflection structurally and/or aesthetically in the selection of the beam sizes. The "Deflection Limits" table on page 1 details deflection limits for various applications.

VERTICALITY

SmartLam GL18 members must not be installed out of plumb more than height/500.

NOTCHES

Large notches and holes in Glulam beams should normally be avoided as they cause abrupt changes in cross section and disrupt the stress flow in the structure. This gives rise to tension perpendicular to the grain and shear stresses around the holes and notches. For this reason, notches seriously reduce the strength of a beam, particularly if located in the tension zone of a beam. Unless specific allowance has been made in the design, no notches shall be made without first obtaining the advice of an engineer. Design rules are set out in AS 1720.1 Timber Engineering Code and should be followed closely when considering notching anywhere in a Glulam beam.

HOLES FOR SERVICES

Horizontal Holes - Like notches, holes in a Glulam beam remove wood fibre, reduce the net area of the beam at the hole location, and introduce stress concentrations. For this reason, horizontal holes in Glulam beams are limited in size and location to maintain the structural integrity of the beam. Figure 2 below shows the zones of a uniformly loaded, simply supported beam where field drilling of holes may be considered.

Field drilled horizontal holes should be for access only and should not be used as attachment points for brackets or other load bearing hardware unless specifically designed as such by the Engineer/Designer.

Regardless of the hole location, the net section of the beam remaining should be checked for flexure and horizontal shear.

Vertical holes - As a rule of thumb, vertical holes drilled through the depth of a Glulam beam cause a reduction in capacity at that location directly proportional to the ratio of 1½ times the

INSTALLATION (cont'd)

diameter of the hole. For example, a 25 mm hole drilled in a 150 mm wide beam would reduce the capacity of the beam at that section by 1/4. For this reason, where it is necessary to drill vertical holes through a Glulam member, the holes should be positioned in areas of the member that are stressed to less than 50% of the design in bending.

Holes for support of heavy equipment - Heavy equipment or

pipng suspended from Glulam should be attached so that the load is applied to the top of the member to avoid tension perpendicular to the grain stresses. Any horizontal holes required for support of significant weight, such as suspended heating and cooling units or main water lines, must be located above the neutral axis of the member and in a zone stressed to less than 50% of the design flexural stresses.

Figure 2 - Zones where horizontal holes are permitted in a uniformly loaded simply supported beam

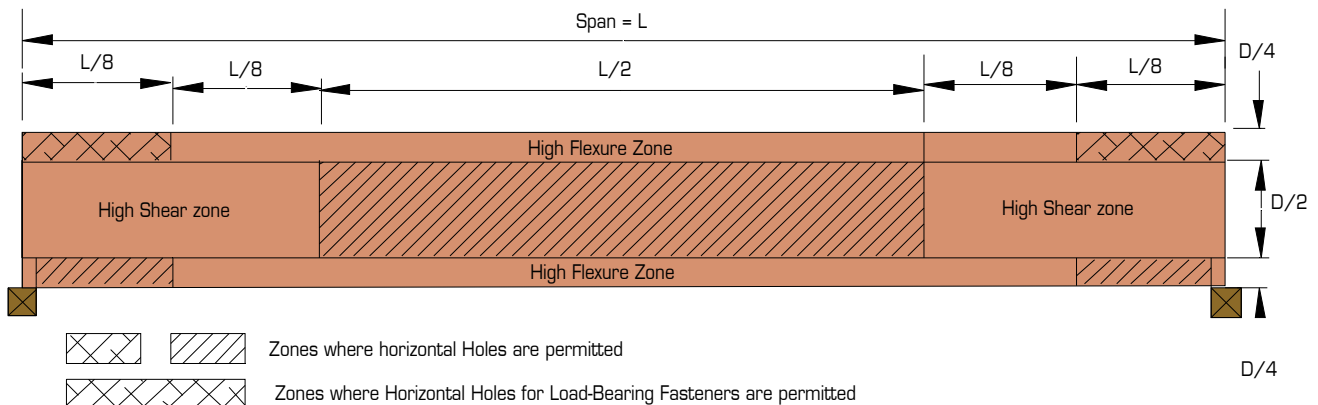

BIRDS MOUTHING

Figure 3 - Birds mouting details for SmartLam GL18

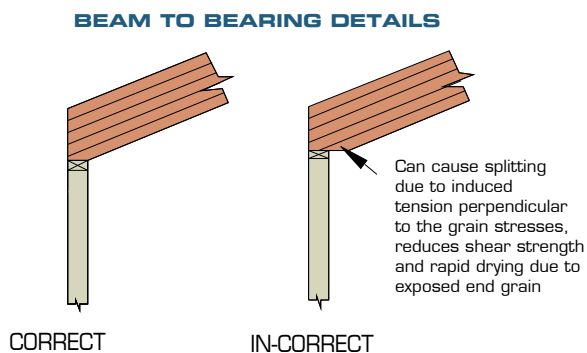

EAVES OVERHANG

Figure 4 - Eaves over hang details for SmartLam GL18

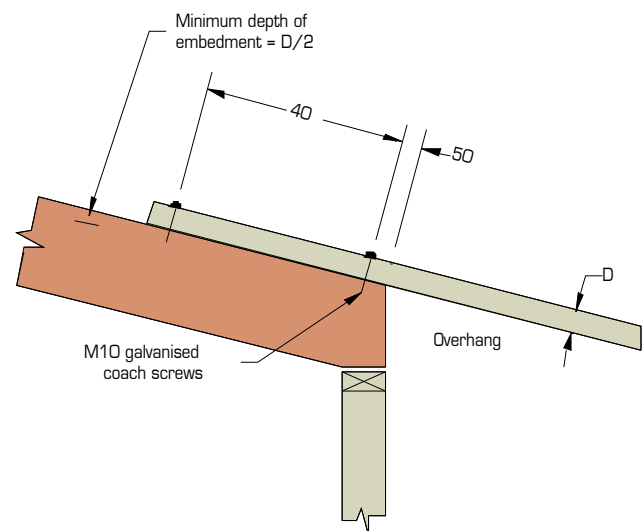

Note:

Refer to AS 1684 Residential timber-framed construction code for overhang member size.

Allowable Eaves overhangs

1. Non Cyclonic Areas

- Beams for flat or similar roofs - Not birds mouthed:
 - Eaves overhang shall not exceed 40% of the actual beam span.
- Beams with conventional pitched roofs - birds mouthed to one third their depth:
 - Sheet roof - 20% of actual beam span
 - Tiled roof - 30% of actual beam span

2. Cyclonic Areas

Recommendations as per above, but reduced as follows:

Non birds mouthed - 25% of actual beam span

birds mouthed-

- Sheet roof - 10% of actual beam span
- Tiled roof - 20% of actual beam span

MULTIPLE SmartLam GL18 SECTION BEAMS

Vertical laminations may be achieved by adopting the principle described in clause 2.3 of AS 1684, however, due to the thickness of SmartLam GL18, nails are NOT suitable for combining SmartLam GL18 beams.

Experience with Glulam beams indicates that multiple member laminations individual components may cup as a result of the ingress of moisture between laminates during construction. The suggested method of vertical lamination shown below provides a greater level of fixity between individual components, and combined with the use of a temporary waterproof membrane and an elastomeric adhesive prevents moisture penetration between the laminates.

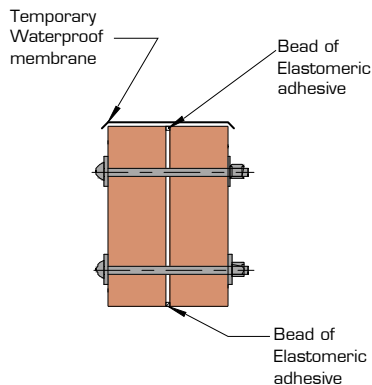

Recommended "during construction" protection from weather for multiple

Notes:

1. Table values are for 40 kg/m² floors.
2. Bolts are to be grade 4.6 commercial bolts conforming to AS 1111. Bolt holes are to be a maximum of 13 mm diameter and are to be located NOT less than 50 mm from either edge.
3. All bolts shall be fitted with a washer at each end, of a size NOT less than that given in AS 1720.1 table 4.12.

TOP LOADED BEAMS (Symmetrical loading)

The edges of the individual sections must be carefully aligned to each other so that the composite beam is flat, allowing the applied loads to be equally shared. It is recommended that there be 2 rows of galvanised M12 bolts at 600 mm centres.

SIDE LOADED BEAMS (Non - symmetrical loading)

When a load is applied to one side of a built-up Glulam or an unbalanced load is applied to both sides, the elements of the built up beam shall be attached such that the applied load is distributed equally to all elements. Like the minimum connection shown above, the connection is made with bolts, with the allowable floor load width supported by either outside member shown in the table below.

Maximum floor Load width supported by either outside member (mm)

Combination (see details below)	12 mm Φ bolts	
	2 rows at 600 ctrs	2 rows at 300 ctrs
Combination 1	7500	15000
Combination 2	5600	11000

Combination 1

2 pieces of
65 or 85 mm

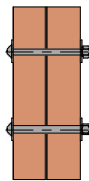

Combination 2

3 pieces of
65 mm

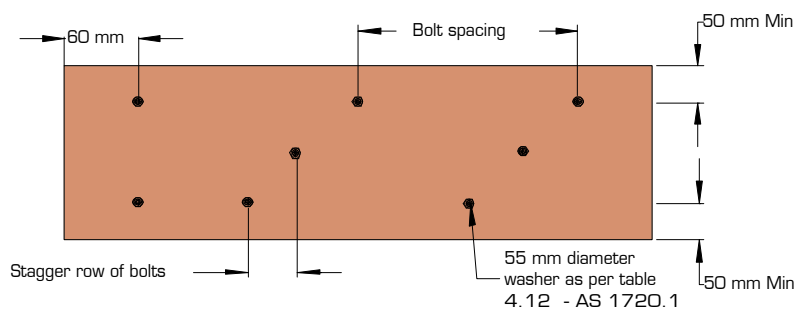
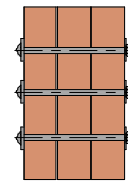

HOW TO USE THE MAXIMUM UNIFORM SIDE LOAD TABLE

Example: see diagram opposite

Beam of 2 SmartLam GL18's loaded on both side (Combination 1)

FLW 1 = 4800 mm, FLW 2 = 5300 mm

Total FLW = 4800 + 5300 = 10100 mm.

1. Use SmartFrame software or these SmartLam GL18 safe load tables to size the two member section to support the FLW of 5100 mm.
2. Choose the larger of the side FLW's carried by the beam, in this case 5300 mm.
3. Enter the table at the "Combination 1" row and scan across to a table value greater than 5300 mm. The first value in the row at 10200 mm is greater than the 5300 mm required.
4. Thus adopt 2 rows of 12 mm Φ x bolts at 600 mm centres

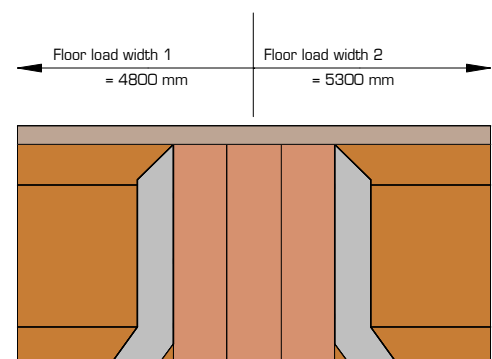

SmartLam GL18 Design /Effective span

Normal structural analysis uses the centreline representation of the member. The term "span" can be defined in a number of ways and these are defined as follows:

Clear span. This is the distance between the faces of any support. It is generally the one easiest to measure and read from the drawings

Nominal span/centre-line span. This is the distance between the centre of the supports. This span is used to determine bending moments and deflections for continuous spanning SmartJoist members

Design span/Effective span. This is the span used for single span members to determine the bending moment, the slenderness of bending members and the deflections. In AS 1720.1, this is the dimension referred to as "L", and is defined below.

Design span/Effective span is the distance between -

- The centre of the bearing at each end of a beam where the bearing lengths have NOT been conservatively sized
- The centre of notional bearing that have been sized appropriately, where the size of the bearing IS conservative.

Diagram (a) shows beam where bearings have been designed appropriately. The effective span is taken as the distance between the centre of each bearing area

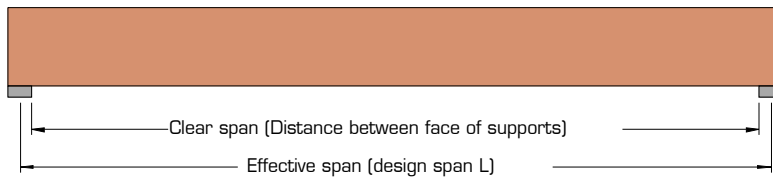
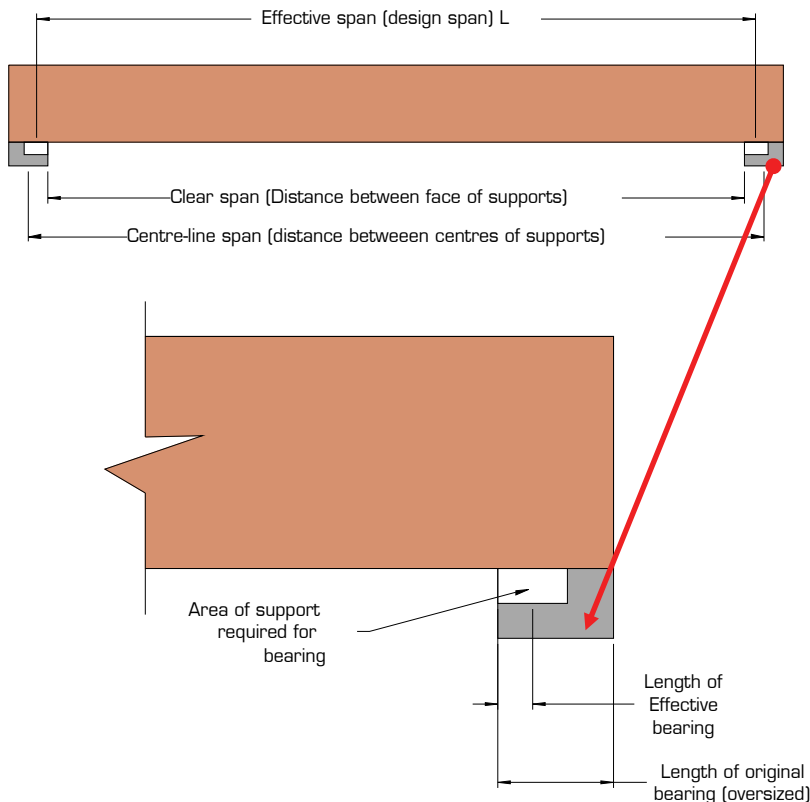

Diagram (b) shows beam where bearings at each end have been oversized. (This is frequently the case for beams that bear onto brickwork or concrete walls where the thickness of the wall is in excess of the area required to give the beam bearing capacity).

To find the correct effective span:

1. Calculate the minimum bearing required to carry the loads satisfactorily
2. Add minimum bearing length to "clear span" distance



span difference	effective span	resultant span description
10% Max	main span	continuous
10 – 30%	1.1 x main span	continuous
Above 30% difference	main span	single

$$\text{span difference} = \frac{(\text{major span} - \text{minor span})}{(\text{major span} + \text{minor span})} \times 100$$

The span to use in the case of unequal continuous spans is the "resultant span description" as shown in the table above. (Note: It is recommended for the most accurate designs, that the SmartFrame software be used.)

SmartLam DURABILITY and WEATHER EXPOSURE RECOMMENDATIONS

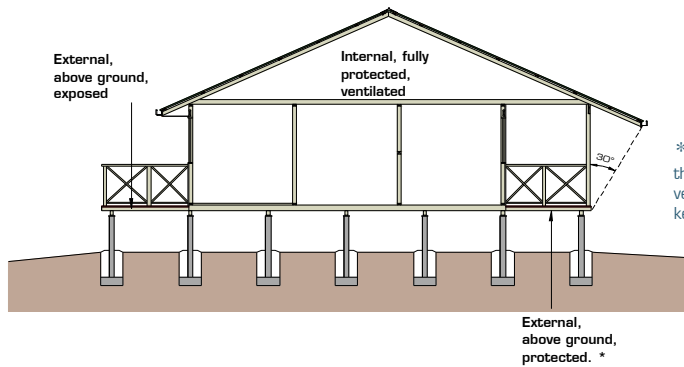

DEFINITIONS OF EXPOSURE

* External timbers are regarded as protected in AS 1684 if they are covered by a roof projection (or similar) at 30° to the vertical and they are well detailed and maintained (painted and kept well ventilated).

SmartLam GL's are manufactured from kiln dried timber (MC less than 15%), and therefore need to be protected from moisture cycling that can occur from:

- ◆ Exposure to direct sun and rain (including during construction)
- ◆ Contact or close exposure with moisture laden porous material (e.g. Concrete blocks)
- ◆ Exposure to extreme environments such as dry heating systems (e.g. slow combustion wood heaters), air conditioning, large north or west facing windows or moisture laden environments such as pool enclosures

SmartLam PROTECTION METHODS

1. During Construction

SmartLam GL's are supplied WITHOUT any short term construction sealer. However if SmartLam GL is expected to be exposed for an extended period or become wet, it is recommended that the beam be sealed with a construction sealer that is compatible with the final paint or varnish finish, or wrapped in plastic to provide protection (plastic must allow for drainage and air circulation to breath).

Examples:

- i. If the SmartLam GL's is installed inside a building without direct exposure to air-conditioning such as in wall cavity, protection to the beam is not required.
- ii. If the SmartLam GL's is installed inside a building with direct exposure to air conditioning or dry heat then a sealer is required.
- iii. If the SmartLam GL's is under the eaves and protected from direct rain and sun, it is recommended that the construction sealer be lightly sanded and a finish coat of compatible premium quality paint be applied. (In accordance with paint manufacturer's specifications).
- iv. If the SmartLam GL's is exposed to the sun or weather refer to "Exterior Applications" below.

2. Exterior Applications

It is **NOT** recommended that ANY SmartLam GL 18 be used in external above ground exposed applications. SmartLam GL's

used in protected exterior applications must be:

- i. Correctly detailed by fully enclosing member with a mechanical barrier such a cement sheet if it is likely to get wet or experiences direct sun
- ii. Mechanical barrier correctly painted with a premium quality protective finish (e.g. light coloured pigmented external paint system) to prevent moisture infiltration.

It is important that an inspection and maintenance programme, based on exposure level and the paint manufacturer's recommendations be prepared.

3. Design & Construction detailing tips

- i. The use of building overhangs and other structures which protect the beams from excessive moisture movement and sun exposure.
- ii. Shielding of the beam from free moisture or direct sun. The use of metal, fibro or plastic shields on the exposed faces or ends of beams is highly recommended to help maintain the beam in an unstressed dry condition.
- iii. All beams should be provided with adequate ventilation so that moisture content within beams will not exceed 15% and moisture gradients across the beam will not occur.
- iv. The use of arrised or round edges on beams to reduce the likelihood of coating failures on sharp edges.
- v. The use of drip edges or other devices which provide a path for free moisture flow away from the timber beam. Refer to detail below.
- vi. Joint detailing should, wherever possible, comply with the following:
 - Keep horizontal contact areas to a minimum, In favour of self draining vertical surfaces.
 - Ventilate joint surfaces by using spacers, wherever possible.
 - Always use compatible fasteners which have adequate corrosion protection and do not cause splitting during installation egg. Hot dipped galvanic coatings or stainless steel.
 - Ensure any moisture entering a joint is not trapped but can adequately drain away from the joint.

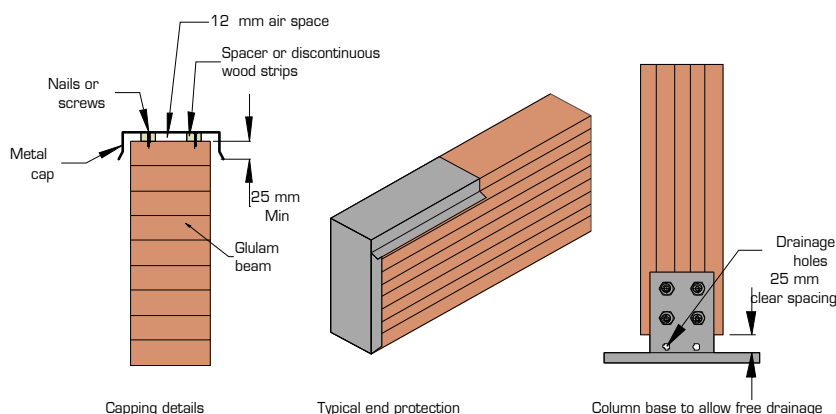

PAINTING SmartLam GL18 BEAMS

One coat of premium quality primer as a minimum should be applied to all surfaces prior to erection of beam and to any cuts or holes drilled. If the first coat of primer, sealant paint or stain fails to dry or adhere within the time expected, do not proceed to any further coats until the first coat has achieved satisfactory dryness and adhesion. If the first coat fails to dry it may be necessary to strip back to bare timber and allow it to weather for another week or two.

1 Paint

- Exterior solid colour acrylic finish. One coat of oil based primer followed by one or two coats of the exterior acrylic finish as required.
- Exterior solid colour oil based enamel. One coat of oil based primer followed by one coat of oil based undercoat (if required) then two coats of the oil based enamel.

2 Stains

Exterior semi-transparent or solid colour penetrating oil based stain or similar. Two or three coats of the stain as required or recommended by the manufacturer.

Water based stains and un-pigmented sealants, oil or water repellents are NOT recommended.

RESIN BLEED

Resin Bleed may be identified by a sticky, clear or white exudation that has a characteristic aromatic odour. It is most com-

monly encountered around knots or other imperfections in the wood and in places where the tree sustained damage. Paint or stain will generally be softened and may even be lifted off by a resin bleed.

If resin bleed occurs the following steps are recommended:

- i. Physically remove the exuded resin from the surface
- ii. Allow to weather for a few days to ensure the bleed has ceased.
- iii. Seal the affected area with a suitable sealant such as Resene Everseal.

Further advice may be obtained from AS 2311

FIRE RATINGS (RESISTANCE)

In a fire, SmartLam GL18 beams have an inherent fire rating. As timber burns, a layer of charcoal forms enclosing a core of timber which is yet unaffected by the fire. This timber core maintains its structural capacity. Hence, dependant upon the loss of material to the charcoal layer, the SmartLam GL18 beam can carry the dead load of the structure for a period of time.

Resistance to fire can be established by reference to AS 1720.4 Fire resistance of structural timber members, using a charring rate of 0.66 mm per minute. Therefore, the strength and stiffness after fire may be assessed using the uncharred residual cross section computed for the period of exposure to the fire.

CHECKING IN SmartLam GL18 GLULAM

One of the advantages of glued laminated timber construction is that while seasoning checks may occur for the same reasons that they do in sawn members, checking in glued laminated timber will generally occur to a much lesser degree because of careful control of the moisture content of timber used for laminating. Checks in wood are separations along the fibres normally occurring across the rings of annual growth resulting from stresses developed during changes in moisture content. Checks in glued laminate timber may appear as openings parallel to the grain on the sides of members.

As wood loses moisture to the surrounding atmosphere, the outer fibres of the member lose moisture at a more rapid rate than do the inner fibres. As outer fibres try to shrink, they are restrained by the inner portion of the member that has higher moisture content. The more rapid the rate of drying, the greater will be the differential in shrinkage between the outer and inner fibres resulting in higher shrinkage stresses.

These resultant stresses perpendicular to the grain of the wood can cause characteristic wood seasoning checks. The

influence of checks on the structural performance of glued laminated timber members is generally minor. Checking can be minimized by careful installation practices that avoid prolonged exposure of the members during construction.

IDENTIFICATION OF CHECKING

Checks occur as transverse separations or openings that are nearly parallel to the grain direction in glued laminated timber and generally follow the grain direction around knots and along sloping grain. Differences in the shrinkage rate of individual laminations used in glued laminated timber tend to concentrate shrinkage stresses at or near glue lines, resulting in checks. Checks are often confused with delamination that occurs when the glue bond is not adequate. The presence of wood fibre separation in these openings is the key distinguishing characteristic of seasoning checks. Openings due to inadequate adhesive bonding may appear as smooth wood surface separations, possibly darkened by the adhesive film, or as glossy surface areas of adhesive with an absence of torn wood fibres.

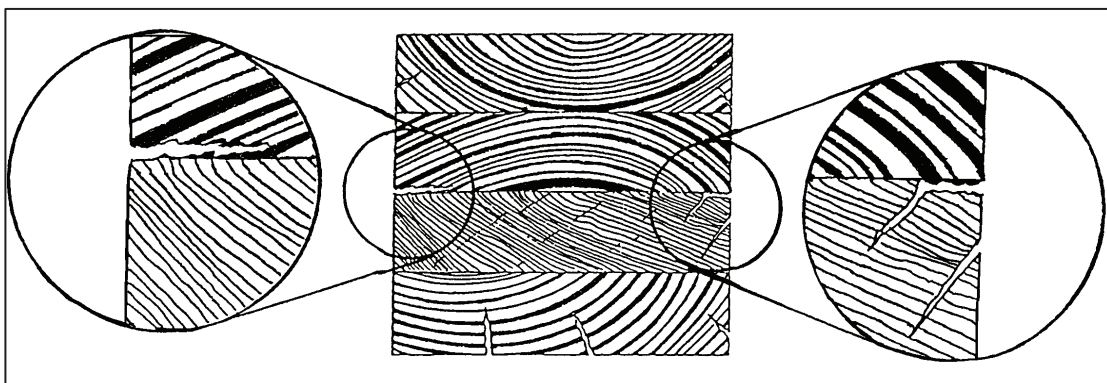

CHECKING IN SmartLam GLULAM (Cont'd)

Checking often occurs along the first glue line adjacent to the outer lamination that may dry more rapidly because a larger surface area of that lamination is exposed to the air. This condition is sometimes aggravated when the outer lamination tends to cup, creating tension perpendicular to grain stresses along or near the first glue line.

SIGNIFICANCE OF CHECKING

In general, checks have little effect on the strength of glued laminated members. Glued laminated members are made from laminations that are thin enough to season readily in kiln drying schedules without developing checks. Checks usually appear on the wide faces of the timber and do not materially affect the shear strength of the laminations. In cases where members are designed for loading parallel to the wide face of the laminations, checks may affect the shear strength of the beam their effect may be evaluated in the same manner as for sawn timber. Seasoning checks in bending members affect only the horizontal shear capacity.

In establishing allowable horizontal shear values, normal checking due to seasoning has been considered.

Checks are usually not of structural importance unless they are significant in depth, occur in the mid-height of the member

QUALITY ASSURANCE

All SmartLam GL18 beams are manufactured in accordance with AS 1328 Glue laminated structural timber and the Glued Laminated Timber Association (GLTAA) Industry standard GLTAA-4-91.

SAFETY PRECAUTIONS:

near the supports, and the design of the member is governed by shear. If these conditions exist, the reduction in shear strength is directly proportional to the ratio of the depth of checks to the width of the bending member. Checks in columns are not of structural importance unless the check develops into a split, thereby increasing the L/d ratio of the column.

ADDITIONAL INFORMATION

While checking is not considered to be of structural significance, the reason for the checking and the means by which further checking may be minimized should be determined.

If there is concern regarding structural adequacy, advice can be obtained from engineers from the SmartFrame Design Centre or a structural engineer experienced and qualified in glued laminated timber technology should evaluate the significance of the checking.

The SmartFrame **technical note - "Evaluation of checking in glued laminated timber (Glulam)"** gives detailed analysis of the modification to structural capacity as a result of severe checking.

The GLTAA Industry standard, GLTAA4-91 prescribes the qualifying process necessary to determine the basic characteristic stresses and stiffness which are assigned to GL18 Glulam. Each joint (finger joint) and face bonds are stringently tested and the results verified by a third party accreditation body to confirm the stated engineering properties of the Glulam beam.

WOOD DUST

(For all Wood Dust, Wood and Wood Products Not Preservative Treated)

CAUTION

WOOD DUST CAN BE PRODUCED BY SAWING, SANDING OR MACHINING WOOD AND WOOD PRODUCTS
FLAMMABLE - POSSIBLE EXPLOSION HAZARD
MAY CAUSE RESPIRATORY, EYE AND SKIN IRRITATION
SOME SPECIES MAY CAUSE DERMATITIS OR ALLERGIC RESPONSE
THE INTERNATIONAL AGENCY FOR RESEARCH ON CANCER (IARC) CLASSIFIES WOOD DUST AS A NASAL
CARCINOGEN IN HUMANS

For Additional information, see the Material Data Sheet

Tilling Timber Pty Ltd
Head Office and Manufacturing
Kilsyth, Victoria.
Ph (03) 9725 0222, Fax (03) 9723 6569
SmartData Customer Helpline 1300 668 690
or at smartdata@tilling.com

LISTS OR TABLES AND CHARTS

Determination of roof load width	12
Floor joists - floor loads only	13
Bearers - floor loads only	14
- single span	14
- continuous span	15
Bearers - wall and roof loads - sheet and tiled roof	16
- single span	16
- continuous span	17
Single/upper storey lintels	18
- wind classification N1-N3	18
- wind classification C1-C3	19
Lower storey lintels supporting load bearing walls and floors	20
Rafters/Roof beam - ceiling attached	21
- wind classification N1-N3	21
- wind classification C1-C3	23
Roof Beams - no ceiling attached	25
- wind classification N1-N3	25
- wind classification C1-C3	27
Ridge or intermediate beam	29
- wind classification N1-N3	29
- wind classification C1-C3	30
Verandah beam	31
- single span wind classification N1-N3	31
- continuous span wind classification N1-N3	32
Verandah beam	33
- single span wind classification C1-C3	33
- continuous span wind classification C1-C3	34
Hip or valley rafter	35
Hanging beam supporting ceiling loads only	36
- wind classification N1-N3	36
- wind classification C1-C3	37
Counter beam supporting hanging beam	38
- wind classification N1-N3	38
- wind classification C1-C3	39
Strutting beams supporting underpurlins	40
- wind classification N1-N3	40
- wind classification C1-C3	41
Strutting /counter beams supporting underpurlins and hanging beam	42
- wind classification N1-N3	42
- wind classification C1-C3	43
Strutting Hanging Beams	44
- wind classification N1-N3	44
- wind classification C1-C3	45
SmartFrame Tools	46

DETERMINATION OF ROOF LOAD WIDTH

ROOF load width (RLW) applies to wall framing members only (e.g.: Bearers under walls etc) and determines the roof load carried by the walls. Typical examples of the RLW are shown below, a far more comprehensive set of diagrams are shown in AS 1684.2

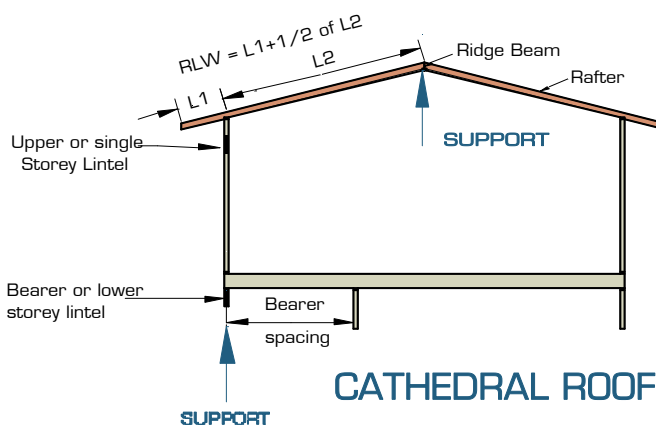
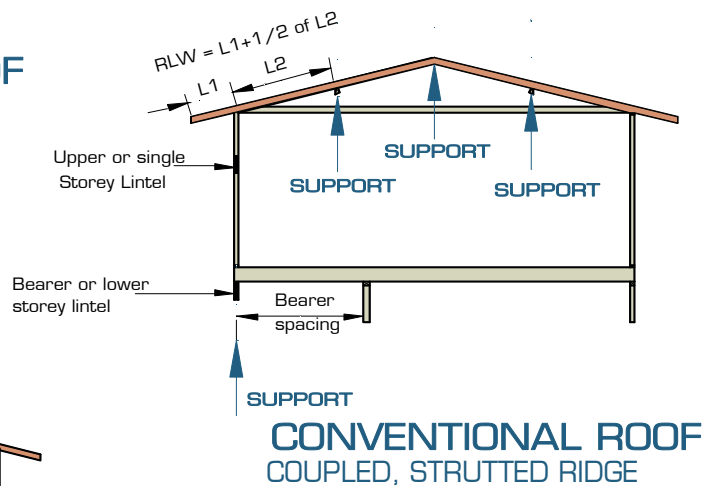
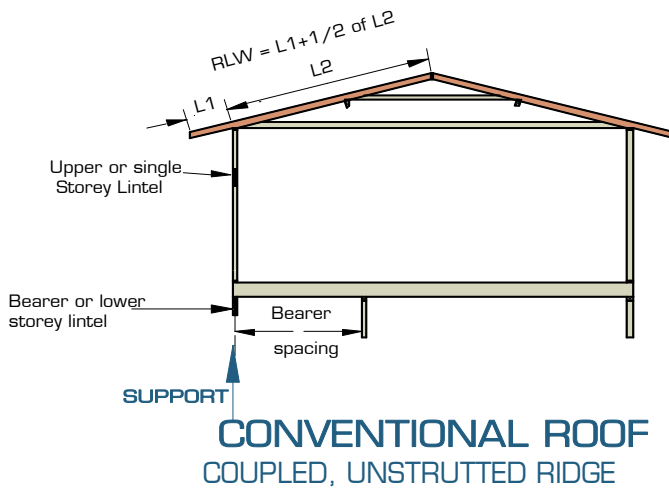
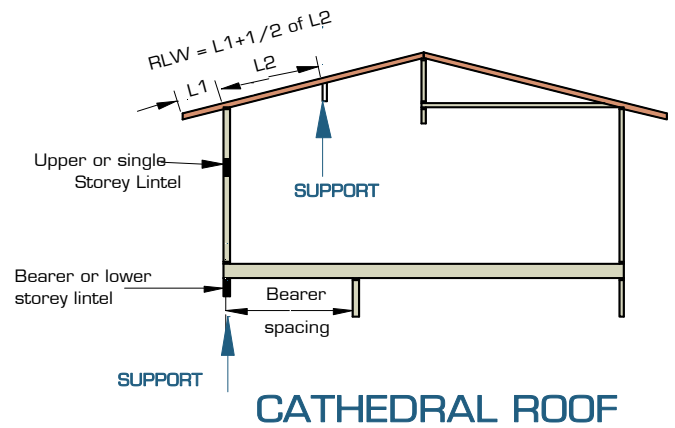
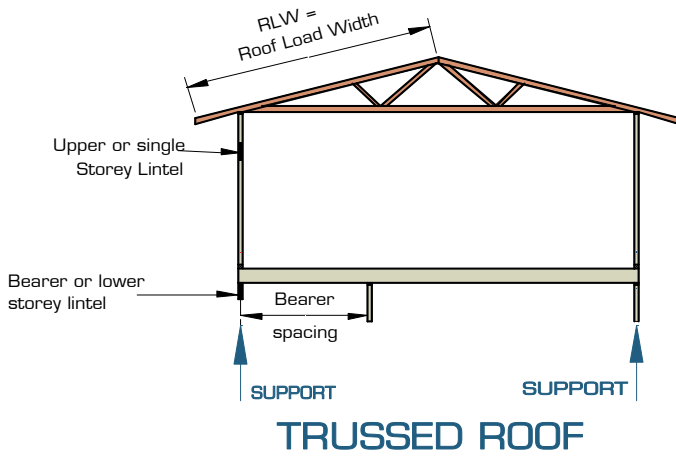

FLOOR JOISTS SUPPORTING FLOOR LOADS ONLY

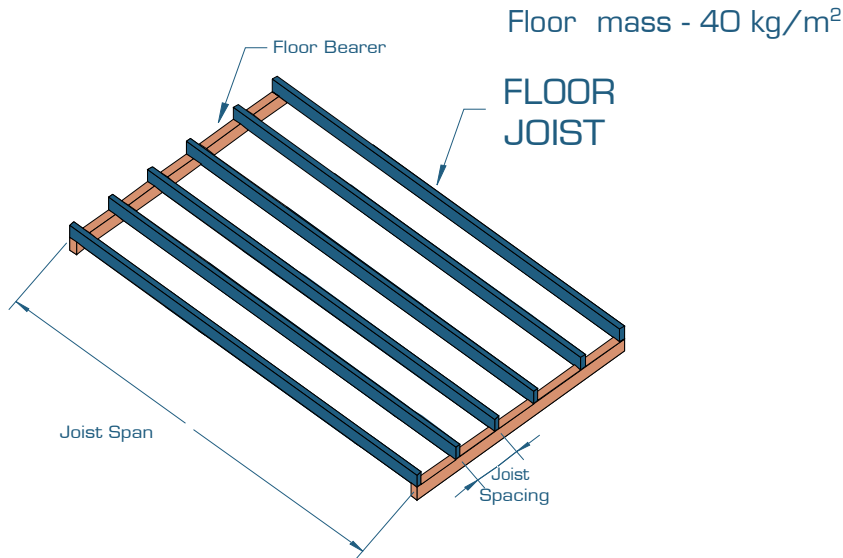

EXAMPLE:

domestic floor loads
single span
joist spacing = 450 mm
joist span = 6000 mm

Enter single span table at 450 mm in joist spacing column, read down to a span equal to or greater than 6000 mm

ADOPT:

SmartLam GL18 - 240x65

Loadings: Permanent - self weight + 40 kg/m² + 0.6 kPa of the live load, live load - 1.5 kPa or floor point load of 1.8 kN

Note: Not all sizes of SmartLam GL18 in this table are stocked in each state. Please check with your supplier before ordering.

Joist spacing (mm)	300	450	600	300	450	600
	Maximum allowable span (mm)					
Member size DxB (mm)	Single span			Continuous span		
150x65	4750	4100	3650	5550	5000	4300
180x65	5450	4950	4500	6350	5750	5300
210x65	6150	5550	5150	7150	6450	6000
240x65	6800	6150	5700	7900	7150	6650
270x65	7400	6700	6250	8600	7800	7250
300x65	8050	7250	6750	9300	8400	7850
330x65	8600	7800	7250	9950	9050	8400
360x65	9200	8300	7750	9950	9650	9000
390x65	9800	8850	8200	10100	9950	9550
420x65	9950	9350	8700	10650	9950	9950
450x65	9950	9850	9150	11200	9950	9950
480x65	10000	9950	9600	11750	9950	9950
510x65	10350	9950	9950	12000	9950	9950
540x65	10800	9950	9950	12000	10300	9950
570x65	11250	9950	9950	12000	10700	10000
150x85	5100	4550	4050	5950	5350	4750
180x85	5850	5300	4900	6800	6150	5700
210x85	6550	5950	5500	7650	6900	6400
240x85	7250	6550	6100	8450	7600	7100
270x85	7950	7150	6650	9200	8300	7750
300x85	8600	7750	7200	9950	9000	8400
330x85	9200	8350	7750	9950	9700	9000
360x85	9850	8900	8300	10200	9950	9600
390x85	9950	9450	8800	10800	9950	9950
420x85	9950	9950	9300	11400	9950	9950
450x85	10100	9950	9800	12000	9950	9950
480x85	10550	9950	9950	12000	10050	9950
510x85	11050	9950	9950	12000	10500	9950
540x85	11500	9950	9950	12000	10950	10250
570x85	10600	10200	9950	12000	11400	10650

NOTES:

- Spans are suitable for solid timber, particle board and ply flooring. floor sheeting glued and nailed to joists will improve floor rigidity. Where heavy overlay material is to be applied, such as a mortar bed tiled or slate floor, the permanent load allowance should be increased to 1.2 kPa. A reduction of joist spacing may be used to accommodate this extra permanent load. A satisfactory result can be achieved by adopting the maximum spans for 600 mm and 450 mm spacing but installing the joists at 450 and 300 mm spacing respectively.
- For beams which are continuous over two unequal spans, the design span and the 'resultant span description' depend upon the percentage span differences between the two spans as shown on page 9.
- D = member depth, B = member breadth, NS = not suitable.
- The above table was based on a maximum DL of 40 (kg/m²), floor live load of 1.5 (kPa), floor point load of 1.8 (kN).
- End bearing lengths = 42 mm at end supports and 58 mm at internal supports for continuous members.
- Not all sizes of SmartLam GL18 in this table are stocked in each state. Please check with your supplier before ordering

SINGLE SPAN FLOOR BEARERS SUPPORTING FLOOR LOADS ONLY

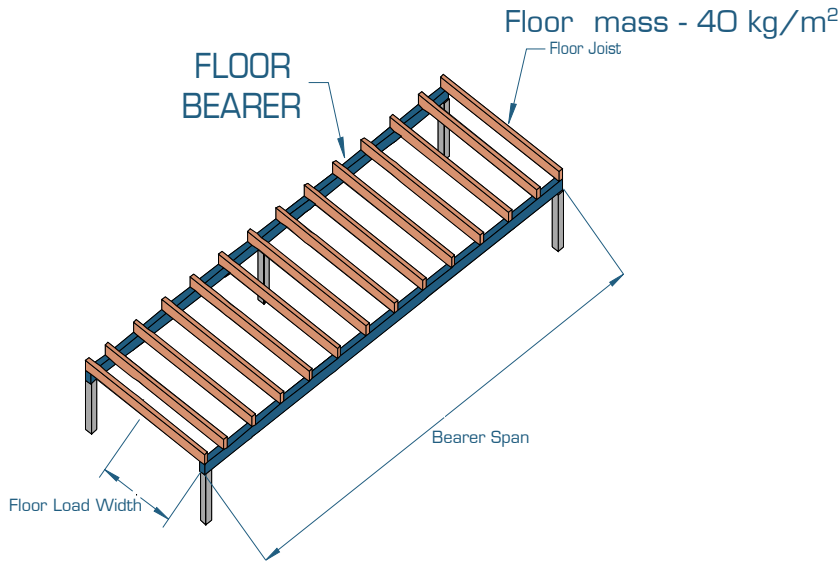

EXAMPLE:

single span bearer = 4000 mm
 floor load width = 6000 mm

Enter single span table at 6000 mm in floor load width column, read down to a span equal to or greater than 4000 mm

ADOPT:

SmartLam GL18 - 330x65 mm

Loadings: Permanent - self weight + 40 kg/m² + 0.6 kPa of the live load, live load - 1.5 kPa or floor point load of 1.8 kN

Note: Not all sizes of SmartLam GL18 in this table are stocked in each state. Please check with your supplier before ordering.

Floor load width (mm)		1200	1800	2400	3000	3600	4200	4800	5400	6000	6600
Member size DxB (mm)	Floor mass (kg/m ²)	Maximum Bearer span (mm)									
		Single span									
150x65	40	3300	2850	2550	2350	2200	2100	2000	1900	1850	1750
180x65	40	3900	3450	3100	2850	2700	2550	2400	2300	2200	2150
210x65	40	4400	3950	3650	3400	3150	3000	2850	2700	2600	2500
240x65	40	4950	4400	4050	3800	3600	3450	3250	3100	3000	2900
270x65	40	5500	4900	4500	4200	4000	3800	3650	3550	3400	3250
300x65	40	6050	5350	4900	4600	4350	4150	4000	3850	3750	3650
330x65	40	6600	5850	5350	5000	4750	4500	4350	4200	4050	3950
360x65	40	7150	6300	5800	5400	5100	4850	4700	4500	4350	4250 ₅
390x65	40	7700	6800	6200	5800	5500	5250	5000	4850	4650 ₅	4550 ₁₀
420x65	40	8300	7300	6650	6200	5850	5600	5350	5150 ₅	5000 ₅	4850 ₁₀
450x65	40	8900	7800	7100	6650	6250	5950	5700 ₅	5500 ₅	5300 ₁₀	5150 ₁₅
480x65	40	9500	8300	7600	7050	6650	6300	6050 ₅	5800 ₁₀	5600 ₁₅	5450 ₁₅
510x65	40	10050	8850	8050	7450	7050	6700 ₅	6400 ₁₀	6150 ₁₀	5950 ₁₅	5750 ₂₀
150x85	40	3600	3100	2800	2600	2450	2300	2200	2100	2000	1950
180x85	40	4200	3750	3400	3150	2950	2800	2650	2550	2450	2350
210x85	40	4750	4250	3900	3700	3450	3250	3100	2950	2850	2750
240x85	40	5350	4750	4400	4100	3900	3750	3600	3400	3300	3150
270x85	40	5900	5250	4850	4550	4300	4100	3950	3800	3700	3600
300x85	40	6500	5800	5300	4950	4700	4500	4300	4150	4050	3900
330x85	40	7100	6300	5800	5400	5100	4900	4700	4500	4350	4250
360x85	40	7750	6850	6250	5850	5500	5250	5050	4850	4700	4550
390x85	40	8350	7350	6750	6300	5950	5650	5400	5200	5050	4900
420x85	40	9000	7900	7250	6750	6350	6050	5800	5550	5400	5200
450x85	40	9650	8500	7750	7200	6800	6450	6150	5950	5750	5550 ₅
480x85	40	10250	9050	8250	7650	7200	6850	6550	6300	6100 ₅	5900 ₁₀
510x85	40	10750	9650	8750	8150	7650	7250	6950	6650 ₅	6450 ₅	6250 ₁₀
540x85	40	11200	10150	9300	8600	8100	7700	7350 ₅	7050 ₅	6800 ₁₀	6550 ₁₅
570x85	40	11700	10550	9800	9100	8550	8100	7750 ₅	7400 ₁₀	7150 ₁₀	6900 ₁₅

CONTINUOUS SPAN FLOOR BEARERS SUPPORTING FLOOR LOADS ONLY

Floor mass - 40 kg/m²

Loadings: Permanent - self weight + 40 kg/m² + 0.6 kPa of the live load, live load - 1.5 kPa or floor point load of 1.8 kN

Note: Not all sizes of SmartLam GL18 in this table are stocked in each state. Please check with your supplier before ordering.

Floor load width (mm)		1200	1800	2400	3000	3600	4200	4800	5400	6000	6600
Member size DxB (mm)	Floor mass (kg/m ²)	Maximum Bearer span (mm)									
		Continuous span									
150x65	40	4050	3650	3150	2800	2550	2350	2200	2050	1950	1850
180x65	40	4600	4200	3750	3350	3050	2800	2650	2500	2350	2250
210x65	40	5150	4700	4350	3900	3550	3300	3050	2900	2750	2600
240x65	40	5700	5150	4800	4450	4050	3750	3500	3300	3100 ₅	2950 ₅
270x65	40	6200	5650	5250	4950	4600	4250	3950 ₅	3700 ₁₀	3500 ₁₅	3350 ₂₀
300x65	40	6700	6100	5650	5350	5100	4700 ₅	4400 ₁₅	4100 ₂₀	3900 ₂₅	3700 ₃₀
330x65	40	7200	6550	6100	5750	5500 ₅	5100 ₁₅	4800 ₂₀	4500 ₃₀	4250 ₃₅	4050 ₄₀
360x65	40	7650	6950	6500	6150	5850 ₁₀	5550 ₂₅	5150 ₃₀	4850 ₃₅	4600 ₄₀	4400 ₅₀
390x65	40	8100	7400	6900	6500 ₅	6200 ₂₀	5950 ₃₀	5550 ₃₅	5250 ₄₅	4950 ₅₀	4700 ₆₀
420x65	40	8550	7800	7250	6850 ₁₀	6550 ₂₅	6300 ₃₅	5950 ₄₅	5600 ₅₅	5300 ₆₀	5050 ₇₀
450x65	40	9000	8200	7650	7250 ₁₅	6900 ₃₀	6650 ₄₀	6350 ₅₅	5950 ₆₀	5650 ₇₀	5350 ₈₀
480x65	40	9450	8600	8000 ₅	7600 ₂₀	7250 ₃₅	6950 ₅₀	6700 ₆₀	6300 ₇₀	6000 ₈₀	5700 ₉₀
510x65	40	9850	9000	8400 ₁₀	7950 ₂₅	7550 ₄₀	7300 ₅₅	7050 ₇₀	6700 ₈₀	6300 ₉₅	6000 ₁₀₀
150x85	40	4300	3900	3600	3200	2900	2700	2500	2350	2250	2100
180x85	40	4900	4450	4150	3850	3500	3200	3000	2850	2700	2550
210x85	40	5500	5000	4650	4400	4050	3750	3500	3300	3100	2950
240x85	40	6050	5500	5150	4850	4600	4300	4000	3750	3550	3400
270x85	40	6600	6000	5600	5300	5050	4800	4500	4250	4000	3800 ₅
300x85	40	7150	6500	6050	5700	5450	5250	5000	4700 ₅	4450 ₁₀	4250 ₁₅
330x85	40	7650	6950	6500	6150	5850	5600	5450 ₁₀	5150 ₁₅	4850 ₂₀	4600 ₂₅
360x85	40	8150	7400	6900	6550	6250	6000 ₅	5800 ₁₅	5550 ₂₅	5250 ₃₀	5000 ₃₅
390x85	40	8600	7850	7350	6950	6600	6350 ₁₀	6150 ₂₀	5950 ₃₀	5650 ₃₅	5400 ₄₀
420x85	40	9100	8300	7750	7300	7000 ₅	6700 ₁₅	6500 ₂₅	6300 ₃₅	6050 ₄₅	5750 ₅₀
450x85	40	9550	8700	8150	7700	7350 ₁₀	7100 ₂₀	6850 ₃₀	6600 ₄₀	6450 ₅₀	6100 ₆₀
480x85	40	10000	9150	8550	8100	7700 ₁₅	7400 ₂₅	7150 ₃₅	6950 ₄₅	6750 ₆₀	6500 ₇₀
510x85	40	10450	9550	8900	8450 ₅	8050 ₂₀	7750 ₃₀	7500 ₄₀	7250 ₅₅	7050 ₆₅	6850 ₇₅
540x85	40	10850	9950	9300	8800 ₁₀	8400 ₂₅	8100 ₃₅	7800 ₄₅	7600 ₆₀	7350 ₇₀	7200 ₈₅
570x85	40	11300	10350	9650	9150 ₁₅	8750 ₃₀	8400 ₄₀	8150 ₅₅	7900 ₆₅	7650 ₈₀	7500 ₉₅

NOTES:

D = member depth, B = member breadth, NS = not suitable.

The above table was based on a maximum DL of 40 (kg/m²), floor live load of 1.5 (kPa), floor point load of 1.8 (kN).

End bearing lengths = 42 mm at end supports and 58 mm at internal supports for continuous members. Subscript values indicate the minimum additional bearing length where required to be greater than 42 mm at end supports and 58 mm at internal supports.

Restraint value for slenderness calculations is 600 mm. (floor joist centres at 600 mm max)

Not all sizes of SmartLam GL18 in this table are stocked in each state. Please check with your supplier before ordering

FLOOR BEARERS SUPPORTING SINGLE STOREY LOAD BEARING WALL - SHEET AND TILED ROOF

Floor mass - 40 kg/m²

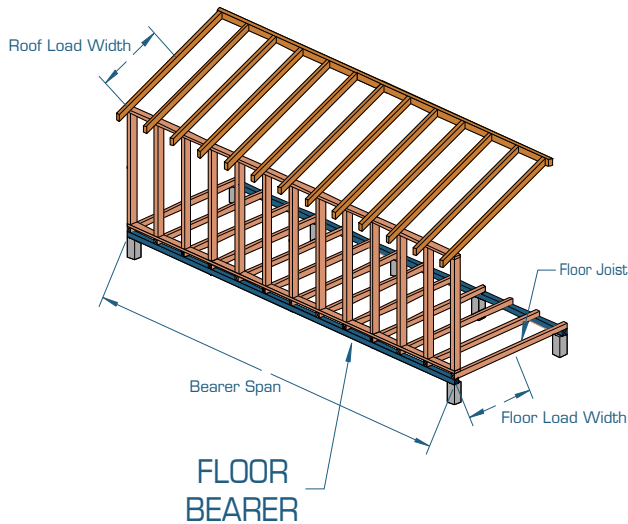

EXAMPLE:

Sheet roof - 40 kg/m²
 roof load width = 1950 mm
 bearer span = 3000 mm (single span)
 floor load width = 3500 mm

Enter single span table at 2400 mm in floor load width column, 4500 roof load width column, read down to a span equal to or greater than 3000 mm in the 40 kg/m² row.

ADOPT:

SmartLam GL18 - 240 x 65

SINGLE SPAN

Floor load width (mm)		1500	1200	7500	1500	2400	7500	1500	4800	7500
Roof load width (mm)		1500	4500	7500	1500	4500	7500	1500	4500	7500
Member size DxB (mm)	Roof mass (kg/m ²)	Maximum Bearer span (mm)								
		Single span								
150x65	40	2550	2250	2100	2200	2050	1900	1850	1750	1650
	75	2400	2050	1800	2150	1900	1700	1800	1650	1550
180x65	40	3100	2750	2500	2700	2450	2300	2200	2100	2050
	75	2900	2450	2200	2600	2250	2050	2150	2000	1850
210x65	40	3600	3250	2950	3150	2900	2700	2600	2500	2400
	75	3450	2900	2600	3050	2650	2450	2550	2350	2200
240x65	40	4050	3700	3400	3600	3350	3150	3000	2850	2750
	75	3850	3350	2950	3500	3100	2800	2950	2700	2550
270x65	40	4450	4050	3800	4000	3750	3550	3400	3250	3100
	75	4250	3750	3350	3900	3500	3150	3350	3050	2850
300x65	40	4900	4450	4150	4350	4100	3900	3750	3600	3450
	75	4650	4100	3750	4250	3850	3550	3700	3400	3200
330x65	40	5300	4850	4500	4750	4450	4200	4050	3900	3800
	75	5050	4400	4050	4600	4150	3850	4000	3750	3550 ₅
360x65	40	5750	5200	4850	5100	4800	4550	4400	4200	4050
	75	5500	4750	4350	4950	4450	4150	4300	4050	3800 ₅
390x65	40	6150	5600	5200	5500	5100	4850	4700	4500	4350 ₅
	75	5900	5100	4650	5300	4800	4450	4600	4300 ₅	4100 ₁₀
420x65	40	6600	6000	5550	5850	5450	5200	5000 ₅	4800 ₅	4650 ₅
	75	6300	5450	4950	5650	5100	4700 ₅	4900 ₅	4600 ₅	4350 ₁₅
450x65	40	7050	6400	5900	6250	5800	5500	5300 ₅	5100 ₅	4900 ₁₀
	75	6700	5800	5250 ₅	6050	5400	5000 ₅	5200 ₅	4850 ₁₀	4600 ₁₅
480x65	40	7500	6750	6300	6650	6200	5850	5650 ₁₀	5400 ₁₀	5200 ₁₀
	75	7150	6150	5600 ₅	6400	5750	5300 ₁₀	5550 ₁₀	5150 ₁₅	4900 ₂₀
510x65	40	7950	7200	6650	7000	6550	6150	5950 ₁₀	5700 ₁₅	5500 ₁₅
	75	7600	6500	5900 ₁₀	6800	6050 ₅	5600 ₁₅	5850 ₁₀	5450 ₁₅	5150 ₂₅
150x85	40	2800	2500	2300	2450	2250	2100	2000	1900	1850
	75	2650	2250	2000	2350	2050	1900	1950	1800	1700
180x85	40	3400	3000	2750	2950	2700	2550	2450	2300	2200
	75	3200	2700	2400	2850	2500	2250	2400	2200	2050
210x85	40	3900	3550	3250	3450	3200	3000	2850	2750	2600
	75	3700	3200	2850	3350	2950	2650	2800	2600	2400
240x85	40	4350	3950	3700	3900	3650	3450	3300	3150	3000
	75	4150	3650	3250	3800	3400	3100	3250	2950	2800
270x85	40	4800	4400	4100	4300	4050	3850	3700	3550	3400
	75	4600	4000	3650	4150	3750	3500	3650	3350	3150
300x85	40	5250	4800	4450	4700	4400	4200	4050	3900	3750
	75	5050	4400	4000	4550	4100	3850	4000	3700	3500
330x85	40	5750	5200	4850	5100	4800	4550	4400	4200	4050
	75	5450	4750	4350	4950	4450	4150	4300	4050	3800
360x85	40	6200	5650	5250	5500	5150	4900	4750	4550	4400
	75	5900	5150	4700	5350	4800	4450	4650	4350	4100
390x85	40	6700	6050	5600	5950	5550	5250	5050	4850	4700
	75	6350	5500	5000	5750	5150	4800	5000	4650	4400
420x85	40	7150	6500	6000	6350	5900	5600	5400	5200	5000
	75	6850	5900	5350	6150	5500	5100	5300	4950	4700 ₅
450x85	40	7650	6900	6400	6750	6300	5950	5750	5500	5300
	75	7300	6300	5700	6550	5850	5400	5650	5250	5000 ₅
480x85	40	8150	7350	6800	7200	6700	6300	6100	5850	5650 ₅
	75	7750	6700	6050	6950	6200	5750	6000	5600 ₅	5250 ₁₀
510x85	40	8700	7800	7200	7650	7100	6700	6450 ₅	6200 ₅	5950 ₅
	75	8250	7050	6400	7400	6600	6050 ₅	6350 ₅	5900 ₅	5550 ₁₅
540x85	40	9200	8250	7650	8100	7500	7050	6800 ₅	6550 ₅	6300 ₁₀
	75	8750	7500	6750	7800	6950	6400 ₅	6700 ₅	6200 ₁₀	5850 ₁₅
570x85	40	9750	8750	8050	8550	7900	7450	7200 ₅	6850 ₁₀	6600 ₁₀
	75	9250	7900	7100 ₅	8250	7350	6750 ₁₀	7050 ₁₀	6550 ₁₀	6150 ₂₀

FLOOR BEARERS SUPPORTING SINGLE STOREY LOAD BEARING WALL - SHEET AND TILED ROOF

CONTINUOUS SPAN

Floor load width (mm)		1200			2400			4800		
Roof load width (mm)		1500	4500	7500	1500	4500	7500	1500	4500	7500
Member size DxB (mm)	Roof mass (kg/m ²)	Maximum Bearer span (mm)								
		Continuous span								
150x65	40	3300	2950	2650	2800	2550	2350	2050	1950	1900
	75	3100	2550	2150	2700	2300	2000	2000	1850	1750
180x65	40	3850	3550	3150	3350	3100	2850	2450	2350	2250
	75	3700	3050	2550	3200	2750	2400	2400	2250	2100
210x65	40	4300	4000	3650	3900	3600	3300	2900	2750	2650
	75	4150	3550	3000	3750	3200	2800	2850	2600	2450
240x65	40	4750	4400	4150	4350	4100	3800	3300	3150	3050 ₅
	75	4600	4050	3400	4200	3650	3200	3250	3000 ₅	2800 ₁₅
270x65	40	5200	4800	4500	4700	4450	4250	3700 ₁₀	3550 ₁₅	3400 ₁₅
	75	5000	4450	3850 ₅	4600	4150	3600 ₁₀	3650 ₁₀	3350 ₂₀	3150 ₂₅
300x65	40	5650	5200	4900	5100	4800	4600 ₅	4100 ₂₀	3950 ₂₅	3800 ₃₀
	75	5400	4800	4250 ₁₅	4950	4550 ₅	4000 ₂₅	4050 ₂₀	3750 ₃₀	3500 ₃₅
330x65	40	6050	5600	5250	5500	5200	4950 ₁₀	4500 ₃₀	4300 ₃₀	4150 ₃₅
	75	5800	5150	4650 ₂₅	5350	4900 ₁₅	4350 ₃₀	4400 ₃₀	4100 ₄₀	3800 ₄₅
360x65	40	6450	5950	5600 ₅	5850	5500 ₅	5250 ₁₅	4850 ₃₅	4650 ₄₀	4450 ₄₅
	75	6200	5500 ₁₀	5050 ₃₀	5700	5200 ₂₀	4700 ₄₀	4750 ₄₀	4400 ₄₅	4150 ₅₅
390x65	40	6850	6300	5950 ₁₀	6200	5850 ₁₀	5600 ₂₅	5200 ₄₅	5000 ₅₀	4800 ₅₅
	75	6600	5850 ₁₅	5400 ₄₀	6050 ₅	5550 ₃₀	5050 ₅₀	5100 ₄₅	4750 ₅₅	4450 ₆₅
420x65	40	7200	6650	6300 ₁₅	6550 ₅	6200 ₁₅	5900 ₃₀	5600 ₅₅	5350 ₆₀	5150 ₆₅
	75	6950	6200 ₂₀	5700 ₄₅	6400 ₁₀	5850 ₃₅	5400 ₆₀	5500 ₅₅	5100 ₇₀	4750 ₈₀
450x65	40	7600	7000	6600 ₂₀	6900 ₁₀	6500 ₂₀	6250 ₃₅	5950 ₆₀	5700 ₇₀	5500 ₇₅
	75	7300	6500 ₂₅	6000 ₅₅	6700 ₁₅	6150 ₄₀	5750 ₇₀	5850 ₆₅	5400 ₈₀	5050 ₉₀
480x65	40	7950	7350 ₅	6950 ₂₅	7250 ₂₀	6850 ₂₅	6550 ₄₀	6300 ₇₀	6050 ₈₀	5800 ₈₅
	75	7650	6800 ₃₀	6300 ₆₀	7050 ₂₀	6450 ₄₅	6050 ₇₅	6200 ₇₅	5750 ₉₀	5350 ₁₀₀
510x65	40	8300	7700 ₁₀	7250 ₃₀	7550 ₂₀	7150 ₃₀	6850 ₄₅	6650 ₈₀	6400 ₉₀	6150 ₁₀₀
	75	8000	7150 ₃₅	6600 ₇₀	7350 ₂₅	6750 ₅₀	6300 ₈₅	6550 ₈₅	6050 ₁₀₀	5650 ₁₁₀
150x85	40	3600	3200	2950	3150	2900	2700	2350	2250	2150
	75	3400	2900	2450	3050	2650	2300	2300	2150	2000
180x85	40	4100	3800	3550	3750	3500	3250	2800	2700	2600
	75	3950	3450	2950	3650	3150	2750	2750	2550	2400
210x85	40	4600	4250	4000	4200	3950	3750	3300	3150	3050
	75	4450	3950	3400	4050	3650	3200	3250	3000	2800
240x85	40	5100	4700	4400	4600	4350	4150	3750	3600	3450
	75	4900	4350	3900	4500	4100	3650	3700	3400	3200
270x85	40	5550	5150	4850	5050	4750	4550	4250	4050	3900 ₅
	75	5350	4750	4400	4900	4500	4100	4150	3850 ₅	3600 ₁₀
300x85	40	6000	5550	5200	5450	5150	4900	4700 ₅	4500 ₁₀	4300 ₁₅
	75	5800	5150	4750	5300	4850	4550 ₁₀	4600 ₁₀	4250 ₁₅	4000 ₂₀
330x85	40	6450	5950	5600	5850	5550	5300	5100 ₁₅	4900 ₂₀	4700 ₂₅
	75	6200	5500	5100 ₅	5700	5200	4900 ₁₅	5000 ₁₅	4650 ₂₅	4350 ₃₀
360x85	40	6850	6350	5950	6250	5900	5650	5500 ₂₀	5300 ₂₅	5100 ₃₀
	75	6600	5900	5450 ₁₅	6100	5550 ₅	5200 ₂₅	5400 ₂₅	5050 ₃₀	4700 ₄₀
390x85	40	7300	6750	6350	6600	6250	6000 ₅	5800 ₂₅	5600 ₃₅	5450 ₄₀
	75	7000	6250	5750 ₂₀	6450	5900 ₁₀	5550 ₃₀	5700 ₃₀	5400 ₄₀	5050 ₅₀
420x85	40	7700	7100	6700	7000	6600	6300 ₁₀	6150 ₃₅	5950 ₄₀	5750 ₄₅
	75	7400	6600	6100 ₂₅	6800	6250 ₁₅	5850 ₃₅	6050 ₃₅	5700 ₄₅	5450 ₆₀
450x85	40	8100	7500	7050	7350	6950 ₅	6650 ₁₅	6450 ₄₀	6250 ₄₅	6050 ₅₀
	75	7800	6950 ₅	6400 ₃₀	7150	6550 ₂₀	6150 ₄₀	6350 ₄₀	6000 ₅₅	5700 ₆₅
480x85	40	8450	7850	7400 ₅	7700	7300 ₅	6950 ₂₀	6800 ₄₅	6550 ₅₀	6350 ₆₀
	75	8150	7250 ₁₀	6700 ₃₅	7500 ₅	6900 ₂₅	6450 ₄₅	6700 ₅₀	6300 ₆₀	6000 ₇₅
510x85	40	8850	8200	7750 ₁₀	8050 ₅	7650 ₁₀	7300 ₂₅	7100 ₅₀	6850 ₅₅	6650 ₆₅
	75	8550	7600 ₁₅	7050 ₄₀	7850 ₅	7200 ₃₀	6750 ₃₅	7000 ₅₅	6600 ₆₅	6300 ₈₅
540x85	40	9250	8550	8050 ₁₅	8400 ₅	7950 ₁₅	7600 ₃₀	7400 ₅₅	7150 ₆₅	6950 ₇₀
	75	8900	7950 ₂₀	7350 ₄₅	8200 ₁₀	7500 ₃₅	7050 ₆₀	7300 ₆₀	6850 ₇₅	6550 ₉₀
570x85	40	9600	8900	8400 ₂₀	8750 ₁₀	8300 ₂₀	7900 ₃₅	7700 ₆₅	7450 ₇₀	7200 ₈₀
	75	9250	8250 ₂₅	7650 ₅₀	8550 ₁₅	7800 ₄₀	7350 ₆₅	7600 ₆₅	7150 ₈₀	6850 ₁₀₀

NOTES:

- D = member depth, B = member breadth, NS = not suitable.
- The above table was based on a maximum DL of 40 (kg/m²), total ground floor mass of 40 (kg/m²), total wall mass of 37 (kg/m²), floor live load of 1.5 (kPa), floor point load of 1.8 (kN)
- The above table was based on a wall height of 2700 mm
- End bearing lengths = 42 mm at end supports and 58 mm at internal supports for continuous members. Subscript values indicate the minimum additional bearing length where required to be greater than 42 mm at end supports and 58 mm at internal supports
- Restraint value for slenderness calculations is 600 mm
- Not all sizes of SmartLam GL18 in this table are stocked in each state. Please check with your supplier before ordering

SINGLE SPAN LINTELS IN SINGLE/UPPER STOREY WALLS AS 4055 CLASSIFICATION N1, N2 AND N3

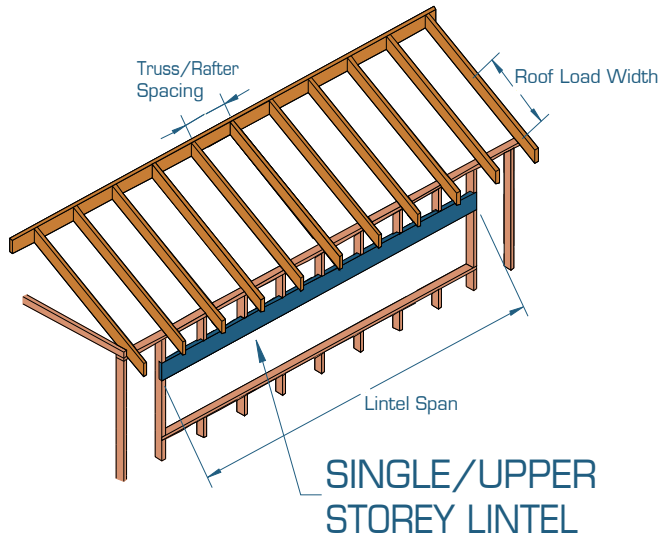

EXAMPLE:

wind speed = N3
 sheet roof - 40 kg/m²
 rafter/truss spacing = 600 mm
 lintel span = 3500 mm
 roof load width = 3900 mm
 Enter span table at 4500 roof load width column, rafter/truss spacing 600 mm, and read down to a span equal to or greater than 3500 mm

ADOPT:

SmartLam GL18 - 210 x 65

Roof load width (mm)		1500		3000		4500		6000		7500	
Rafter/Truss spacing (mm)		600	1200	600	1200	600	1200	600	1200	600	1200
Member size DxB (mm)	Roof mass (kg/m ²)	Maximum Lintel span (mm)									
		Single span									
150x65	40	3950	3900	3300	3250	2950	2950	2700	2650	2450	2300
	90	3200	3150	2650	2700	2300	2300	2100	2050	1900	1900
180x65	40	4600	4600	3850	3800	3450	3400	3150	3150	2900	2800
	90	3700	3650	3050	3050	2750	2800	2500	2550	2300	2300
210x65	40	5300	5300	4350	4350	3900	3900	3600	3550	3400	3250
	90	4200	4200	3500	3450	3100	3100	2900	2900	2700	2750
240x65	40	5950	5950	4900	4900	4400	4350	4050	4000	3800	3750
	90	4750	4750	3900	3900	3500	3450	3250	3200	3050	3000
270x65	40	6650	6650	5450	5450	4850	4850	4500	4450	4200	4200
	90	5300	5300	4350	4300	3850	3850	3550	3550	3350	3300
300x65	40	7350	7350	6000	6000	5350	5350	4900	4900	4600	4600
	90	5850	5800	4750	4750	4250	4250	3900	3850	3650	3650
330x65	40	8100	8100	6600	6600	5850	5800	5350	5350	5050	5000
	90	6350	6350	5200	5200	4600	4600	4250	4250	4000	3950
360x65	40	8850	8850	7200	7150	6350	6350	5850	5800	5450	5450
	90	6950	6900	5600	5600	5000	4950	4600	4550	4300	4300 ₅
390x65	40	9600	9600	7800	7800	6850	6850	6300	6250	5900	5850
	90	7500	7500	6050	6050	5350	5350	4950	4900	4600	4600
420x65	40	10400	10400	8400	8400	7400	7350	6750	6750	6300	6300
	90	8100	8100	6500	6500	5750	5700	5250	5250	4950 ₅	4900 ₁₀
450x65	40	11250	11200	9050	9050	7950	7900	7250	7200	6750 ₅	6750 ₁₀
	90	8700	8700	6950	6950	6150	6100	5600	5600 ₅	5250 ₅	5250 ₁₀
480x65	40	11950	11950	9700	9650	8500	8450	7700	7700	7200 ₅	7150 ₅
	90	9300	9300	7450	7400	6550	6500	6000 ₅	5950 ₅	5550 ₁₀	5550 ₅
510x65	40	12000	12000	10350	10350	9050	9050	8250 ₅	8200 ₅	7650 ₁₀	7650 ₁₀
	90	9950	9950	7900	7900	6950	6950	6350 ₅	6300	5900 ₁₀	5850 ₁₀
150x85	40	4250	4250	3500	3500	3150	3150	2950	2950	2750	2700
	90	3400	3400	2850	2850	2500	2600	2250	2300	2100	2100
180x85	40	4950	4950	4100	4100	3700	3650	3400	3350	3200	3200
	90	4000	3950	3300	3250	2950	2950	2750	2750	2550	2600
210x85	40	5650	5650	4700	4700	4200	4200	3900	3850	3650	3600
	90	4550	4550	3750	3750	3350	3350	3100	3100	2900	2950
240x85	40	6400	6400	5300	5300	4700	4700	4350	4350	4100	4100
	90	5100	5150	4200	4200	3750	3750	3500	3450	3250	3250
270x85	40	7150	7150	5900	5850	5250	5250	4850	4800	4550	4500
	90	5700	5700	4700	4650	4150	4150	3850	3800	3600	3550
300x85	40	7950	7950	6500	6500	5800	5750	5300	5300	5000	4950
	90	6300	6250	5150	5150	4600	4550	4200	4200	3950	3950
330x85	40	8750	8700	7150	7100	6350	6300	5800	5800	5450	5450
	90	6900	6900	5600	5600	5000	4950	4600	4550	4300	4300
360x85	40	9550	9550	7800	7800	6900	6850	6300	6300	5900	5900
	90	7500	7500	6100	6050	5400	5400	4950	4950	4650	4600
390x85	40	10400	10350	8450	8450	7450	7450	6800	6800	6350	6350
	90	8150	8150	6600	6550	5800	5800	5300	5350	5000	4950
420x85	40	11300	11250	9150	9150	8050	8050	7350	7300	6850	6850
	90	8800	8800	7100	7050	6250	6200	5700	5700	5350	5350
450x85	40	12000	12000	9850	9800	8650	8600	7900	7850	7350	7300
	90	9500	9450	7600	7600	6650	6650	6100	6050	5700	5650
480x85	40	12000	12000	10550	10550	9250	9250	8450	8400	7850	7850
	90	10150	10150	8100	8100	7150	7100	6500	6500	6050	6050
510x85	40	12000	12000	11250	11250	9900	9850	9000	9000	8350	8350 ₅
	90	10900	10850	8650	8650	7550	7550	6900	6900	6400 ₅	6400
540x85	40	8250	8300	11750	11750	10550	10500	9550	9550	8850 ₅	8850
	90	12000	12000	9200	9200	8050	8000	7300	7300 ₅	6800 ₅	6800
570x85	40	7750	7750	12000	12000	11050	11050	10150 ₅	10150 ₅	9400 ₅	9400 ₁₀
	90	12000	12000	9750	9750	8500	8500	7700	7700 ₅	7200 ₁₀	7150 ₁₀

SINGLE SPAN LINTELS IN SINGLE/UPPER STOREY WALLS AS 4055 CLASSIFICATION C1, C2 AND C3

Roof load width (mm)		1500		3000		4500		6000		7500	
Rafter/truss spacing (mm)		600	1200	600	1200	600	1200	600	1200	600	1200
Member size DxB (mm)	Roof mass (kg/m ²)	Maximum Lintel span (mm)									
		Single span									
150x65	40	3600	3400	2550	2450	2000	1800	1700	1350	1500	1050
	90	3200	3150	2650	2600	2150	2000	1800	1500	1600	1200
180x65	40	4300	4250	3000	2900	2500	2350	2100	1950	1850	1550
	90	3700	3650	3050	3050	2600	2500	2250	2100	1950	1700
210x65	40	5050	5050	3600	3400	2850	2800	2500	2400	2200	2150
	90	4200	4200	3500	3450	3000	2900	2600	2550	2350	2250
240x65	40	5800	5700	4050	3950	3300	3150	2850	2750	2550	2450
	90	4750	4750	3900	3900	3500	3300	2950	2900	2650	2600
270x65	40	6500	6450	4600	4550	3750	3550	3200	3050	2850	2800
	90	5300	5300	4350	4300	3850	3750	3400	3200	3000	2900 ₁₀
300x65	40	7250	7250	5100	5050	4150	4000	3600	3400	3200	3050
	90	5850	5800	4750	4750	4250	4250	3750	3600	3350	3200 ₅
330x65	40	7950	7850	5550	5500	4550	4500	3900	3750	3500 ₅	3350
	90	6350	6350	5200	5200	4600	4600	4100 ₅	4000	3700 ₁₀	3500 ₅
360x65	40	8600	8550	6050	5950	4950	4900	4250	4150 ₅	3800	3650
	90	6950	6900	5600	5600	5000	4950	4450 ₅	4400 ₁₀	3950 ₁₀	3850 ₁₀
390x65	40	9250	9250	6500	6450	5300	5250	4600	4550 ₅	4050	3950
	90	7500	7500	6050	6050	5350	5350	4800 ₁₀	4800 ₁₅	4250 ₁₅	4200 ₂₅
420x65	40	9900	9900	6950	6950	5650	5600	4900 ₅	4900 ₅	4350 ₁₀	4300 ₁₅
	90	8100	8100	6500	6500	5750 ₅	5700 ₅	5150 ₁₀	5100 ₁₅	4600 ₁₅	4550 ₂₀
450x65	40	10600	10550	7450	7400	6050	5950	5200 ₅	5200 ₅	4700 ₅	4650 ₁₀
	90	8700	8700	6950	6950	6150 ₁₀	6100 ₅	5450 ₁₀	5400 ₁₅	4900 ₂₅	4900 ₂₅
480x65	40	11250	11200	7900	7850	6400	6350	5550 ₁₀	5450 ₅	4950 ₁₅	4950 ₁₅
	90	9300	9300	7450	7400	6550 ₅	6500 ₅	5850 ₁₅	5700 ₂₀	5200 ₂₀	5150 ₂₅
510x65	40	11900	11850	8350	8250	6800 ₅	6750	5900 ₁₀	5750 ₁₅	5250 ₁₅	5200 ₁₅
	90	9950	9950	7900	7900	6950 ₁₅	6950 ₁₅	6150 ₂₀	6050 ₂₀	5500 ₂₀	5400 ₂₅
150x85	40	4100	4000	2850	2800	2350	2200	2000	1750	1750	1400
	90	3400	3400	2850	2850	2450	2350	2100	1950	1850	1550
180x85	40	4950	4900	3500	3300	2800	2750	2450	2350	2150	2050
	90	4000	3950	3300	3250	2950	2850	2550	2450	2300	2150
210x85	40	5650	5650	4050	3950	3300	3150	2850	2750	2550	2450
	90	4550	4550	3750	3750	3350	3300	3000	2900	2650	2600
240x85	40	6400	6400	4650	4650	3800	3650	3250	3100	2900	2800
	90	5100	5150	4200	4200	3750	3750	3450	3250	3050	2950
270x85	40	7150	7150	5250	5200	4250	4150	3700	3500	3300	3150
	90	5700	5700	4700	4650	4150	4150	3850	3700	3450	3300
300x85	40	7950	7950	5850	5750	4750	4750	4100	4000	3700	3500
	90	6300	6250	5150	5150	4600	4550	4200	4200	3850	3700
330x85	40	8750	8700	6400	6300	5200	5150	4500	4450	4000	3850
	90	6900	6900	5600	5600	5000	4950	4600	4550	4200 ₅	4100 ₁₀
360x85	40	9550	9550	6900	6900	5650	5550	4900	4850	4350	4250 ₅
	90	7500	7500	6100	6050	5400	5400	4950	4950 ₅	4550	4500 ₅
390x85	40	10400	10350	7450	7450	6100	5950	5250	5200	4700	4700
	90	8150	8150	6600	6550	5800	5800	5300	5350 ₅	4900 ₁₀	4900 ₁₀
420x85	40	11200	11250	8000	7950	6500	6400	5600	5550 ₅	5000 ₅	5000 ₅
	90	8800	8800	7100	7050	6250	6200	5700 ₅	5700 ₁₀	5250 ₅	5200 ₁₀
450x85	40	12000	12000	8500	8450	6950	6900	6000	5900	5350	5300 ₅
	90	9500	9450	7600	7600	6650	6650	6100 ₁₀	6050 ₅	5600 ₁₅	5500 ₂₀
480x85	40	12000	12000	9050	9000	7350	7350	6350	6250	5650 ₁₀	5600 ₁₅
	90	10150	10150	8100	8100	7150	7100 ₅	6500 ₁₀	6500 ₁₀	5950 ₁₅	5850 ₂₀
510x85	40	12000	12000	9600	9550	7800	7750	6700	6650	6000 ₁₀	5900 ₁₀
	90	10900	10850	8650	8650	7550 ₅	7550 ₅	6900 ₁₅	6900 ₂₀	6300 ₂₀	6200 ₁₅
540x85	40	8250	8300	10100	10050	8200	8150 ₅	7100 ₅	7050 ₁₀	6350 ₁₀	6250 ₁₀
	90	12000	12000	9200	9200	8050 ₁₀	8000 ₁₀	7300 ₁₅	7300 ₁₅	6650 ₂₀	6600 ₁₅
570x85	40	7750	7750	10600	10550	8650	8550 ₅	7450 ₅	7450 ₁₀	6650 ₁₀	6600 ₁₀
	90	12000	12000	9750	9750	8500 ₁₀	8500 ₁₀	7700 ₁₅	7700 ₁₅	7000 ₂₅	6950 ₃₀

NOTES:

1. D = member depth, B = member breadth, NS = not suitable.
2. Minimum bearing length = 35 mm at end supports. Subscript values indicate the minimum additional bearing length where required to be greater than 35 mm.
3. Restraint value for slenderness calculations is 600 mm.
4. Not all sizes of SmartLam GL18 in this table are stocked in each state. Please check with your supplier before ordering

SINGLE SPAN LINTELS IN LOWER STOREY WALLS AS 4055 CLASSIFICATION N1, N2, N3 & C1

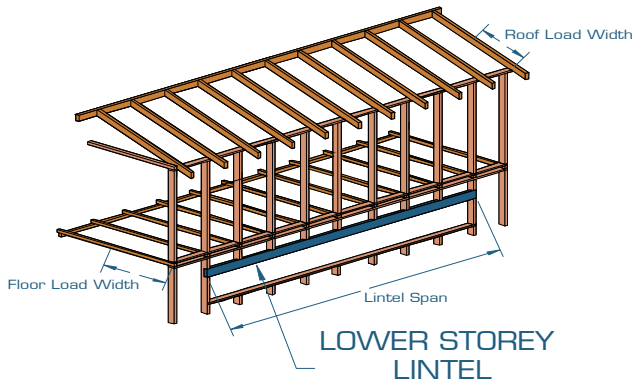

EXAMPLE:

wind speed = N3
 sheet roof - 40 kg/m²
 rafter/truss spacing = 600 mm
 lintel span = 3500 mm
 roof load width = 3900 mm
 floor load width = 1200 mm
 Enter span table at 4500 roof load width column, floor load width 1200 mm, and read down to a span equal to or greater than 3500 mm

ADOPT:

SmartLam GL18 - 240 x 65

Roof load width (mm)		1500			3000			4500			6000		
Floor load width (mm)		1200	2400	3600	1200	2400	3600	1200	2400	3600	1200	2400	3600
Member size DxB (mm)	Roof mass (kg/m ²)	Maximum Lintel span (mm)											
		Single span											
150x65	40	2800	2450	2200	2650	2350	2100	2450	2200	2050	2350	2100	1950
	90	2600	2300	2100	2250	2100	1950	2050	1950	1800	1900	1800	1700
180x65	40	3300	2900	2650	3050	2800	2550	2900	2700	2450	2800	2550	2400
	90	3000	2750	2550	2750	2500	2350	2500	2350	2200	2300	2200	2100
210x65	40	3750	3300	3050	3500	3150	2950	3300	3050	2850	3150	2950	2750
	90	3450	3150	2900	3100	2900	2750	2850	2750	2600	2700	2550	2450
240x65	40	4200	3700	3400	3900	3550	3250	3700	3400	3150	3550	3300	3100
	90	3850	3500	3250	3450	3250	3050	3200	3050	2900	3000	2900	2800
270x65	40	4650	4100	3750	4300	3900	3600	4100	3750	3500	3900	3600	3400
	90	4250	3850	3600	3800	3550	3350	3550	3350	3200	3350	3200	3050
300x65	40	5100	4500	4100	4750	4250	3950	4500	4100	3850	4250	3950	3700
	90	4650	4250	3900	4200	3900	3700	3850	3650	3500	3650	3500	3350
330x65	40	5550	4900	4450	5150	4650	4300	4900	4450	4150	4650	4300	4050
	90	5100	4600	4250	4550	4250	4000	4200	4000	3800	3950	3800	3650
360x65	40	6050	5300	4800	5600	5000	4650	5300	4800	4500	5050	4650	4350
	90	5500	4950	4600	4900	4550	4300	4550	4300	4100	4250	4050	3900 ₅
390x65	40	6500	5700	5150	6050	5400	4950	5700	5200	4800	5400	5000	4700
	90	5950	5350	4950	5300	4900	4600	4850	4600	4400 ₅	4550	4350 ₅	4200 ₅
420x65	40	7000	6100	5500	6500	5800	5300	6100	5550	5150	5800	5350	5000 ₅
	90	6400	5750	5300	5650	5250	4950 ₅	5200	4900	4700 ₅	4900	4650 ₅	4450 ₁₀
450x65	40	7500	6500	5900	6950	6200	5700 ₅	6500	5900	5500 ₅	6200	5700	5350 ₅
	90	6800	6100	5650 ₅	6050	5600	5250 ₅	5550	5250 ₅	5000 ₁₀	5200 ₅	4950 ₁₀	4750 ₁₅
480x65	40	8000	6950	6250 ₅	7400	6600	6050 ₅	6950	6300	5850 ₅	6600	6050	5650 ₅
	90	7300	6500	6000 ₅	6450	5950	5600 ₁₀	5900	5550 ₅	5300 ₁₀	5550 ₅	5250 ₁₀	5050 ₁₅
510x65	40	8550	7400	6650 ₅	7900	7000	6400 ₁₀	7400	6700	6200 ₁₀	7000	6450	6000 ₁₀
	90	7750	6900	6350 ₁₀	6850	6300 ₅	5900 ₁₀	6250 ₅	5900 ₁₀	5600 ₁₅	5850 ₁₀	5550 ₁₅	5350 ₂₀
150x85	40	3050	2700	2400	2850	2550	2300	2700	2450	2250	2550	2350	2150
	90	2800	2500	2300	2500	2300	2100	2250	2100	2000	2100	2000	1900
180x85	40	3550	3150	2850	3300	3000	2750	3150	2900	2700	3000	2800	2600
	90	3250	2950	2750	2950	2750	2550	2700	2550	2400	2550	2400	2300
210x85	40	4000	3550	3250	3750	3400	3150	3550	3250	3050	3400	3150	3000
	90	3700	3350	3100	3350	3100	2950	3100	2950	2800	2900	2800	2700
240x85	40	4500	4000	3650	4200	3800	3500	4000	3650	3400	3800	3550	3300
	90	4150	3750	3500	3750	3500	3300	3450	3250	3100	3250	3100	3000
270x85	40	5000	4400	4000	4650	4200	3900	4400	4050	3750	4200	3900	3650
	90	4600	4150	3850	4100	3850	3600	3800	3600	3450	3600	3450	3300
300x85	40	5500	4850	4400	5100	4600	4250	4850	4450	4150	4600	4300	4000
	90	5050	4550	4200	4500	4200	3950	4200	3950	3750	3950	3750	3600
330x85	40	6000	5250	4800	5600	5000	4650	5300	4800	4500	5000	4650	4350
	90	5500	4950	4600	4900	4600	4300	4550	4300	4100	4250	4100	3900
360x85	40	6550	5700	5200	6050	5450	5000	5700	5200	4850	5450	5050	4700
	90	5950	5400	4950	5300	4950	4650	4900	4650	4400	4600	4400	4200
390x85	40	7100	6150	5600	6550	5850	5400	6150	5600	5200	5850	5400	5050
	90	6450	5800	5350	5750	5300	5000	5300	5000	4750	4950	4700	4500
420x85	40	7600	6650	6000	7050	6300	5750	6650	6000	5600	6300	5800	5400
	90	6950	6200	5700	6150	5700	5350	5650	5350	5050	5300	5050	4850 ₅
450x85	40	8200	7100	6400	7550	6750	6150	7100	6450	5950	6750	6200	5800
	90	7450	6650	6100	6600	6100	5700	6050	5700	5400	5650	5400	5150 ₅
480x85	40	8750	7550	6850	8100	7200	6550	7600	6850	6350	7200	6600	6150
	90	7950	7100	6500	7000	6500	6050	6450	6050	5750 ₅	6000	5700 ₅	5450 ₁₀
510x85	40	9350	8050	7250	8600	7650	6950	8050	7300	6750	7650	7000	6550 ₅
	90	8450	7550	6900	7450	6900	6450 ₅	6800	6400	6050 ₅	6350	6050 ₅	5800 ₁₀
540x85	40	9950	8550	7700 ₅	9150	8100	7400 ₅	8550	7750	7150 ₅	8100	7400	6900 ₅
	90	9000	8000	7300 ₅	7900	7300	6800 ₅	7200	6800 ₅	6400 ₁₀	6750 ₅	6400 ₁₀	6100 ₁₀
570x85	40	10550	9100	8150 ₅	9700	8600	7800 ₅	9100	8200	7550 ₅	8600	7850	7300 ₅
	90	9550	8500	7750 ₅	8350	7700	7200 ₁₀	7650	7150 ₅	6750 ₁₀	7100 ₅	6750 ₁₀	6450 ₁₅

NOTES:

- D = member depth, B = member breadth, NS = not suitable.
- Total Upper floor mass of 40 (kg/m²), floor live load of 1.5 (kPa), floor point load of 1.8 (kN).
- Minimum bearing length = 35 mm at end supports. Subscript values indicate the minimum additional bearing length where required to be greater than 35 mm.
- Restraint value for slenderness calculations is 600 mm.
- Not all sizes of SmartLam GL18 in this table are stocked in each state. Please check with your supplier before ordering

SINGLE/CONTINUOUS SPAN ROOF RAFTER AS 4055 CLASSIFICATION N1, N2 AND N3 WITH CEILING ATTACHED

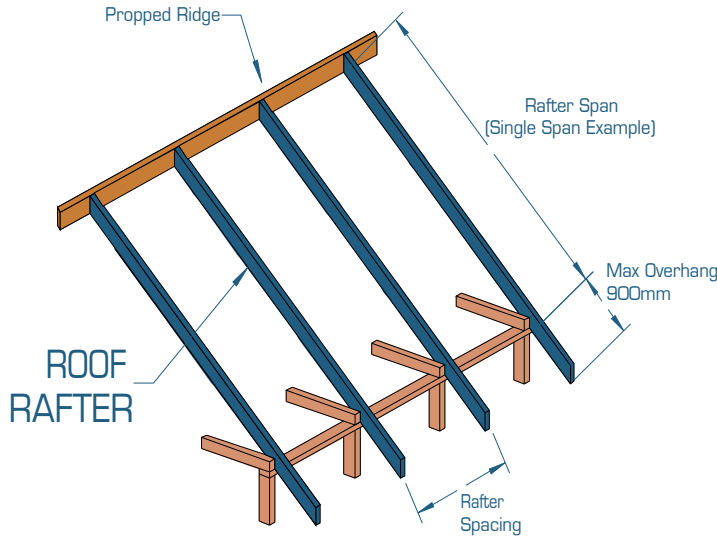

EXAMPLE:

wind speed = N3
 sheet roof - 40 kg/m²
 rafter/truss spacing = 600 mm
 rafter span = 5000 mm
 Enter span table at rafter spacing of 600 mm, and read down to a span equal to or greater than 5000 mm

ADOPT:

SmartLam GL18 - 150 x 65

Note: Not all sizes of SmartLam GL18 in this table are stocked in each state. Please check with your supplier before ordering.

Roof load width (mm)		450	600	900	1200	450	600	900	1200
Member size DxB (mm)	Roof mass (kg/m ²)	Maximum Rafter span (mm)							
		Single span				Continuous span			
150x65	30	6600	6250	5600	5150	7600	7200	6650	6300
	40	6250	5800	5150	4700	7200	6800	6300	5850
	75	5250	4800	4200	3850	6350	6000	5300	4850
	90	4950	4550	4000	3600	6100	5650	5000	4600
180x65	30	7650	7250	6600	6200	8550	8150	7550	7150
	40	7250	6800	6200	5700	8150	7750	7150	6750
	75	6250	5800	5100	4650	7250	6800	6250	5800
	90	6000	5500	4800	4400	6950	6550	6000	5500
210x65	30	8700	8200	7500	7000	9450	9050	8400	7950
	40	8200	7700	7000	6550	9050	8600	7950	7500
	75	7150	6650	6000	5450	8050	7600	7000	6550
	90	6850	6350	5650	5150	7800	7300	6700	6300
240x65	30	9750	9200	8400	7850	10300	9850	9200	8750
	40	9200	8650	7850	7350	9850	9400	8750	8250
	75	8000	7450	6750	6250	8850	8350	7700	7200
	90	7650	7100	6400	5950	8550	8050	7400	6900
270x65	30	10750	10200	9350	8700	11100	10650	10000	9500
	40	10200	9600	8700	8100	10650	10200	9500	8950
	75	8850	8250	7450	6900	9600	9100	8350	7850
	90	8500	7900	7100	6600	9250	8750	8050	7550
300x65	30	11800	11200	10250	9600	11850	11400	10700	10200
	40	11200	10550	9600	8900	11400	10950	10200	9650
	75	9750	9050	8150	7550	10300	9750	9000	8450
	90	9300	8650	7800	7200	9950	9400	8650	8150
330x65	30	12000	12000	11200	10450	12000	12000	11400	10850
	40	12000	11500	10450	9750	12000	11650	10850	10300
	75	10600	9900	8900	8250	11000	10450	9650	9050
	90	10150	9450	8500	7850	10650	10050	9250	8700
360x65	30	12000	12000	12000	11350	12000	12000	12000	11550
	40	12000	12000	11350	10550	12000	12000	11550	10950
	75	11500	10750	9650	8900	11650	11100	10250	9650
	90	11000	10250	9200	8500	11300	10700	9850	9250
390x65	30	12000	12000	12000	12000	12000	12000	12000	12000
	40	12000	12000	12000	11400	12000	12000	12000	11550
	75	12000	11600	10400	9600	12000	11700	10850	10200
	90	11900	11050	9900	9150	11900	11300	10450	9800
420x65	30	12000	12000	12000	12000	12000	12000	12000	12000
	40	12000	12000	12000	12000	12000	12000	12000	12000
	75	12000	12000	11150	10300	12000	12000	11400	10750
	90	12000	11850	10600	9800	12000	11900	11000	10350
450x65	30	12000	12000	12000	12000	12000	12000	12000	12000
	40	12000	12000	12000	12000	12000	12000	12000	12000
	75	12000	12000	11950	11000	12000	12000	11950	11300
	90	12000	12000	11350	10450	12000	12000	11550	10900
480x65	30	12000	12000	12000	12000	12000	12000	12000	12000
	40	12000	12000	12000	12000	12000	12000	12000	12000
	75	12000	12000	12000	11750	12000	12000	12000	11800
	90	12000	12000	12000	11150	12000	12000	12000	11400
510x65	30	12000	12000	12000	12000	12000	12000	12000	12000
	40	12000	12000	12000	12000	12000	12000	12000	12000
	75	12000	12000	12000	12000	12000	12000	12000	12000
	90	12000	12000	12000	11850	12000	12000	12000	11900

SINGLE/CONTINUOUS SPAN ROOF RAFTER AS 4055 CLASSIFICATION N1, N2 AND N3 WITH CEILING ATTACHED [Cont'd]

Roof load width (mm)		450	600	900	1200	450	600	900	1200
Member size DxB (mm)	Roof mass (kg/m ²)	Maximum Rafter span (mm)							
		Single span				Continuous span			
150x85	30	6950	6600	6050	5600	7900	7550	7000	6650
	40	6600	6200	5600	5150	7550	7200	6650	6250
	75	5700	5250	4600	4200	6700	6350	5750	5250
	90	5400	4950	4350	3950	6500	6100	5450	5000
180x85	30	8050	7650	7000	6600	8900	8500	7950	7550
	40	7650	7200	6600	6150	8500	8100	7550	7100
	75	6700	6250	5550	5100	7650	7200	6600	6200
	90	6400	5950	5250	4800	7350	6950	6350	5950
210x85	30	9150	8650	8000	7500	9800	9450	8850	8400
	40	8650	8200	7500	7000	9450	9000	8400	7950
	75	7600	7100	6450	6000	8500	8050	7400	6950
	90	7300	6800	6150	5650	8200	7750	7100	6650
240x85	30	10200	9700	8950	8400	10700	10300	9650	9200
	40	9700	9150	8400	7850	10300	9850	9200	8700
	75	8500	7950	7200	6700	9300	8800	8150	7650
	90	8150	7600	6900	6400	9000	8500	7800	7350
270x85	30	11300	10750	9900	9300	11500	11100	10450	9950
	40	10750	10150	9300	8700	11100	10650	9950	9450
	75	9450	8800	8000	7400	10050	9550	8850	8300
	90	9050	8450	7600	7050	9750	9250	8500	8000
300x85	30	12000	11800	10850	10200	12000	11850	11200	10700
	40	11800	11150	10200	9550	11850	11400	10700	10150
	75	10350	9700	8750	8150	10800	10250	9500	8950
	90	9950	9250	8350	7750	10450	9950	9150	8600
330x85	30	12000	12000	11850	11150	12000	12000	11900	11400
	40	12000	12000	11150	10400	12000	12000	11400	10850
	75	11300	10550	9550	8850	11500	10950	10150	9600
	90	10850	10100	9100	8450	11150	10600	9800	9250
360x85	30	12000	12000	12000	12000	12000	12000	12000	12000
	40	12000	12000	12000	11300	12000	12000	12000	11500
	75	12000	11450	10350	9600	12000	11600	10800	10200
	90	11750	10950	9850	9150	11850	11250	10400	9800
390x85	30	12000	12000	12000	12000	12000	12000	12000	12000
	40	12000	12000	12000	12000	12000	12000	12000	12000
	75	12000	12000	11150	10350	12000	12000	11400	10800
	90	12000	11850	10650	9850	12000	11900	11000	10400
420x85	30	12000	12000	12000	12000	12000	12000	12000	12000
	40	12000	12000	12000	12000	12000	12000	12000	12000
	75	12000	12000	12000	11100	12000	12000	12000	11350
	90	12000	12000	11450	10550	12000	12000	11600	10950
450x85	30	12000	12000	12000	12000	12000	12000	12000	12000
	40	12000	12000	12000	12000	12000	12000	12000	12000
	75	12000	12000	12000	11900	12000	12000	12000	11900
	90	12000	12000	12000	11300	12000	12000	12000	11500
480x85	30	12000	12000	12000	12000	12000	12000	12000	12000
	40	12000	12000	12000	12000	12000	12000	12000	12000
	75	12000	12000	12000	12000	12000	12000	12000	12000
	90	12000	12000	12000	12000	12000	12000	12000	12000
510x85	30	12000	12000	12000	12000	12000	12000	12000	12000
	40	12000	12000	12000	12000	12000	12000	12000	12000
	75	12000	12000	12000	12000	12000	12000	12000	12000
	90	12000	12000	12000	12000	12000	12000	12000	12000

NOTES:

1. D = member depth, B = member breadth, NS = not suitable.
2. The above table was based on a batten spacing of 900 mm
3. Maximum birds mouth depth = 30 % of rafter depth
4. End bearing lengths = 35 mm at end supports and 35 mm at internal supports for continuous members. Subscript values Indicate the minimum additional bearing length where required to be greater than 35 mm at end supports and 35 mm at internal supports
5. Construction loads shall not be applied to overhangs until a 190x19 (minimum) timber fascia or other fascia of equivalent stiffness is rigidly and permanently attached to the end of rafter overhangs
6. Rafter spacing up to 1200 mm
7. Not all sizes of SmartLam GL18 in this table are stocked in each state. Please check with your supplier before ordering

SINGLE/CONTINUOUS SPAN ROOF RAFTER AS 4055 CLASSIFICATION C1, C2 AND C3 WITH CEILING ATTACHED

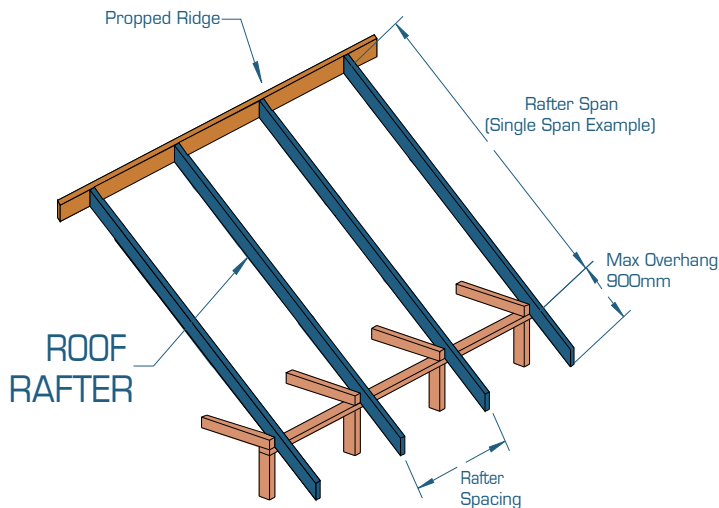

EXAMPLE:

wind speed = C3
 sheet roof - 40 kg/m²
 rafter/truss spacing = 600 mm
 rafter span = 5000 mm
 Enter span table at rafter spacing of 600 mm, and read down to a span equal to or greater than 5000 mm

ADOPT:

SmartLam GL18 - 150 x 65

Note: Not all sizes of SmartLam GL18 in this table are stocked in each state. Please check with your supplier before ordering.

Roof load width (mm)		450	600	900	1200	450	600	900	1200
Member size DxB (mm)	Roof mass (kg/m ²)	Maximum Rafter span (mm)							
		Single span				Continuous span			
150x65	30	6300	5750	5000	4250	7350	6300	5050	4250
	40	6250	5750	5000	4300	7200	6350	5050	4300
	75	5250	4800	4200	3850	6350	6000	5250	4450
	90	4950	4550	4000	3600	6100	5650	5000	4500
180x65	30	7600	6900	6000	5150	8550	7600	6100	5150
	40	7250	6800	6000	5200	8150	7650	6150	5200
	75	6250	5800	5100	4650	7250	6800	6250	5400
	90	6000	5500	4800	4400	6950	6550	6000	5450
210x65	30	8700	8050	7000	6050	9450	8900	7150	6050
	40	8200	7700	7000	6150	9050	8600	7200	6150
	75	7150	6650	6000	5450	8050	7600	7000	6350
	90	6850	6350	5650	5150	7800	7300	6700	6300
240x65	30	9750	9200	8000	7000	10300	9850	8200	7000
	40	9200	8650	7850	7050	9850	9400	8300	7050
	75	8000	7450	6750	6250	8850	8350	7700	7200
	90	7650	7100	6400	5950	8550	8050	7400	6900
270x65	30	10750	10200	9000	7900	11100	10650	9250	7900
	40	10200	9600	8700	8000	10650	10200	9350	8000
	75	8850	8250	7450	6900	9600	9100	8350	7850
	90	8500	7900	7100	6600	9250	8750	8050	7550
300x65	30	11800	11200	10050	8800	11850	11400	10300	8800
	40	11200	10550	9600	8900	11400	10950	10200	8900
	75	9750	9050	8150	7550	10300	9750	9000	8450
	90	9300	8650	7800	7200	9950	9400	8650	8150
330x65	30	12000	12000	11050	9650	12000	12000	11300	9650
	40	12000	11500	10450	9750	12000	11650	10850	9750
	75	10600	9900	8900	8250	11000	10450	9650	9050
	90	10150	9450	8500	7850	10650	10050	9250	8700
360x65	30	12000	12000	12000	10500	12000	12000	12000	10500
	40	12000	12000	11350	10550	12000	12000	11550	10600
	75	11500	10750	9650	8900	11650	11100	10250	9650
	90	11000	10250	9200	8500	11300	10700	9850	9250
390x65	30	12000	12000	12000	11300	12000	12000	12000	11300
	40	12000	12000	12000	11400	12000	12000	12000	11450
	75	12000	11600	10400	9600	12000	11700	10850	10200
	90	11900	11050	9900	9150	11900	11300	10450	9800
420x65	30	12000	12000	12000	12000	12000	12000	12000	12000
	40	12000	12000	12000	12000	12000	12000	12000	12000
	75	12000	12000	11150	10300	12000	12000	11400	10750
	90	12000	11850	10600	9800	12000	11900	11000	10350
450x65	30	12000	12000	12000	12000	12000	12000	12000	12000
	40	12000	12000	12000	12000	12000	12000	12000	12000
	75	12000	12000	11950	11000	12000	12000	11950	11300
	90	12000	12000	11350	10450	12000	12000	11550	10900
480x65	30	12000	12000	12000	12000	12000	12000	12000	12000
	40	12000	12000	12000	12000	12000	12000	12000	12000
	75	12000	12000	12000	11750	12000	12000	12000	11800
	90	12000	12000	12000	11150	12000	12000	12000	11400
510x65	30	12000	12000	12000	12000	12000	12000	12000	12000
	40	12000	12000	12000	12000	12000	12000	12000	12000
	75	12000	12000	12000	12000	12000	12000	12000	12000
	90	12000	12000	12000	11850	12000	12000	12000	11900

SINGLE/CONTINUOUS SPAN ROOF RAFTER AS 4055 CLASSIFICATION C1, C2 AND C3 WITH CEILING ATTACHED [Cont'd]

Roof load width (mm)		450	600	900	1200	450	600	900	1200
Member size DxB (mm)	Roof mass (kg/m ²)	Maximum Rafter span (mm)							
		Single span				Continuous span			
150x85	30	6900	6300	5500	4900	7900	7250	5800	4900
	40	6600	6200	5500	4950	7550	7200	5850	4950
	75	5700	5250	4600	4200	6700	6350	5750	5100
	90	5400	4950	4350	3950	6500	6100	5450	5000
180x85	30	8050	7550	6600	5950	8900	8500	7000	5950
	40	7650	7200	6600	6000	8500	8100	7050	6000
	75	6700	6250	5550	5100	7650	7200	6600	6200
	90	6400	5950	5250	4800	7350	6950	6350	5950
210x85	30	9150	8650	7700	6950	9800	9450	8200	7000
	40	8650	8200	7500	6950	9450	9000	8300	7050
	75	7600	7100	6450	6000	8500	8050	7400	6950
	90	7300	6800	6150	5650	8200	7750	7100	6650
240x85	30	10200	9700	8750	7950	10700	10300	9450	8050
	40	9700	9150	8400	7850	10300	9850	9200	8100
	75	8500	7950	7200	6700	9300	8800	8150	7650
	90	8150	7600	6900	6400	9000	8500	7800	7350
270x85	30	11300	10750	9850	8950	11500	11100	10450	9100
	40	10750	10150	9300	8700	11100	10650	9950	9200
	75	9450	8800	8000	7400	10050	9550	8850	8300
	90	9050	8450	7600	7050	9750	9250	8500	8000
300x85	30	12000	11800	10850	9950	12000	11850	11200	10150
	40	11800	11150	10200	9550	11850	11400	10700	10150
	75	10350	9700	8750	8150	10800	10250	9500	8950
	90	9950	9250	8350	7750	10450	9950	9150	8600
330x85	30	12000	12000	11850	10950	12000	12000	11900	11100
	40	12000	12000	11150	10400	12000	12000	11400	10850
	75	11300	10550	9550	8850	11500	10950	10150	9600
	90	10850	10100	9100	8450	11150	10600	9800	9250
360x85	30	12000	12000	12000	11950	12000	12000	12000	12000
	40	12000	12000	12000	11300	12000	12000	12000	11500
	75	12000	11450	10350	9600	12000	11600	10800	10200
	90	11750	10950	9850	9150	11850	11250	10400	9800
390x85	30	12000	12000	12000	12000	12000	12000	12000	12000
	40	12000	12000	12000	12000	12000	12000	12000	12000
	75	12000	12000	11150	10350	12000	12000	11400	10800
	90	12000	11850	10650	9850	12000	11900	11000	10400
420x85	30	12000	12000	12000	12000	12000	12000	12000	12000
	40	12000	12000	12000	12000	12000	12000	12000	12000
	75	12000	12000	12000	11100	12000	12000	12000	11350
	90	12000	12000	11450	10550	12000	12000	11600	10950
450x85	30	12000	12000	12000	12000	12000	12000	12000	12000
	40	12000	12000	12000	12000	12000	12000	12000	12000
	75	12000	12000	12000	11900	12000	12000	12000	11900
	90	12000	12000	12000	11300	12000	12000	12000	11500
480x85	30	12000	12000	12000	12000	12000	12000	12000	12000
	40	12000	12000	12000	12000	12000	12000	12000	12000
	75	12000	12000	12000	12000	12000	12000	12000	12000
	90	12000	12000	12000	12000	12000	12000	12000	12000
510x85	30	12000	12000	12000	12000	12000	12000	12000	12000
	40	12000	12000	12000	12000	12000	12000	12000	12000
	75	12000	12000	12000	12000	12000	12000	12000	12000
	90	12000	12000	12000	12000	12000	12000	12000	12000

NOTES:

1. D = member depth, B = member breadth, NS = not suitable.
2. The above table was based on a batten spacing of 900 mm
3. Maximum birds mouth depth = 30 % of rafter depth
4. End bearing lengths = 35 mm at end supports and 35 mm at internal supports for continuous members. Subscript values Indicate the minimum additional bearing length where required to be greater than 35 mm at end supports and 35 mm at internal supports
5. Construction loads shall not be applied to overhangs until a 190x19 (minimum) timber fascia or other fascia of equivalent stiffness is rigidly and permanently attached to the end of rafter overhangs
6. Rafter spacing up to 1200 mm
7. Not all sizes of SmartLam GL18 in this table are stocked in each state. Please check with your supplier before ordering

SINGLE/CONTINUOUS SPAN ROOF RAFTER AS 4055 CLASSIFICATION N1, N2 AND N3 WITHOUT CEILING ATTACHED

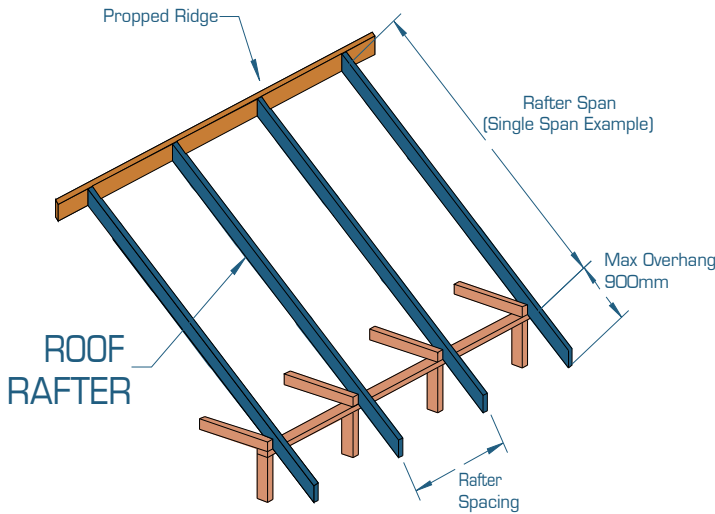

EXAMPLE:

wind speed = N3
 sheet roof - 40 kg/m²
 rafter/truss spacing = 600 mm
 rafter span = 5000 mm
 Enter table at rafter spacing of 600 mm, and read down to a span equal to or greater than 5000 mm

ADOPT:

SmartLam GL18 - 150 x 65

Note: Not all sizes of SmartLam GL18 in this table are stocked in each state. Please check with your supplier before ordering.

Roof load width (mm)		450	600	900	1200	450	600	900	1200
Member size DxB (mm)	Roof mass (kg/m ²)	Maximum Rafter span (mm)							
		Single span				Continuous span			
150x65	10	6900	6550	5700	5200	8800	8500	7450	6350
	20	6900	6550	5700	5200	8050	7750	7200	6450
	40	6250	5800	5150	4700	7200	6800	6300	5850
	60	5600	5150	4550	4150	6650	6300	5650	5200
180x65	10	8600	7850	6850	6200	9800	9500	9000	7650
	20	8250	7850	6850	6200	9050	8700	8150	7750
	40	7250	6800	6200	5700	8150	7750	7150	6750
	60	6600	6200	5500	5000	7550	7150	6550	6150
210x65	10	10050	9150	8000	7250	10700	10450	10000	9000
	20	9350	8900	8000	7250	10000	9600	9050	8600
	40	8200	7700	7000	6550	9050	8600	7950	7500
	60	7500	7000	6350	5900	8400	7950	7300	6900
240x65	10	11400	10450	9100	8300	11600	11300	10850	10350
	20	10450	9950	9100	8300	10850	10450	9850	9400
	40	9200	8650	7850	7350	9850	9400	8750	8250
	60	8400	7850	7100	6600	9200	8750	8050	7550
270x65	10	12000	11750	10250	9350	12000	12000	11650	11300
	20	11550	11000	10200	9350	11650	11300	10650	10200
	40	10200	9600	8700	8100	10650	10200	9500	8950
	60	9350	8700	7900	7300	10000	9500	8750	8250
300x65	10	12000	12000	11400	10350	12000	12000	12000	12000
	20	12000	12000	11200	10350	12000	12000	11400	10950
	40	11200	10550	9600	8900	11400	10950	10200	9650
	60	10250	9600	8650	8050	10700	10200	9400	8900
330x65	10	12000	12000	12000	11400	12000	12000	12000	12000
	20	12000	12000	12000	11400	12000	12000	12000	11650
	40	12000	11500	10450	9750	12000	11650	10850	10300
	60	11200	10450	9450	8750	11400	10850	10050	9500
360x65	10	12000	12000	12000	12000	12000	12000	12000	12000
	20	12000	12000	12000	12000	12000	12000	12000	12000
	40	12000	12000	11350	10550	12000	12000	11550	10950
	60	12000	11350	10250	9500	12000	11550	10700	10100
390x65	10	12000	12000	12000	12000	12000	12000	12000	12000
	20	12000	12000	12000	12000	12000	12000	12000	12000
	40	12000	12000	12000	11400	12000	12000	12000	11550
	60	12000	12000	11050	10200	12000	12000	11300	10700
420x65	10	12000	12000	12000	12000	12000	12000	12000	12000
	20	12000	12000	12000	12000	12000	12000	12000	12000
	40	12000	12000	12000	12000	12000	12000	12000	12000
	60	12000	12000	11850	10950	12000	12000	11900	11250
450x65	10	12000	12000	12000	12000	12000	12000	12000	12000
	20	12000	12000	12000	12000	12000	12000	12000	12000
	40	12000	12000	12000	12000	12000	12000	12000	12000
	60	12000	12000	12000	11750	12000	12000	12000	11800
480x65	10	12000	12000	12000	12000	12000	12000	12000	12000
	20	12000	12000	12000	12000	12000	12000	12000	12000
	40	12000	12000	12000	12000	12000	12000	12000	12000
	60	12000	12000	12000	12000	12000	12000	12000	12000
510x65	10	12000	12000	12000	12000	12000	12000	12000	12000
	20	12000	12000	12000	12000	12000	12000	12000	12000
	40	12000	12000	12000	12000	12000	12000	12000	12000
	60	12000	12000	12000	12000	12000	12000	12000	12000

SINGLE/CONTINUOUS SPAN ROOF RAFTER AS 4055 CLASSIFICATION N1, N2 AND N3 WITHOUT CEILING ATTACHED [Cont'd]

Roof load width (mm)		450	600	900	1200	450	600	900	1200
Member size DxB (mm)	Roof mass (kg/m ²)	Maximum Rafter span (mm)							
		Single span				Continuous span			
150x85	10	7800	7150	6250	5650	9000	8750	8350	7300
	20	7450	7100	6250	5650	8350	8050	7550	7200
	40	6600	6200	5600	5150	7550	7200	6650	6250
	60	6050	5600	4950	4500	7000	6650	6100	5650
180x85	10	9350	8550	7500	6800	10000	9800	9400	8850
	20	8600	8200	7500	6800	9400	9050	8500	8100
	40	7650	7200	6600	6150	8500	8100	7550	7100
	60	7000	6600	5950	5450	7950	7550	6950	6550
210x85	10	10550	10000	8750	7950	10950	10700	10300	9950
	20	9750	9300	8650	7950	10300	9950	9450	9000
	40	8650	8200	7500	7000	9450	9000	8400	7950
	60	8000	7500	6800	6350	8850	8400	7750	7300
240x85	10	11700	11400	10000	9050	11800	11550	11150	10850
	20	10850	10400	9700	9050	11150	10850	10300	9850
	40	9700	9150	8400	7850	10300	9850	9200	8700
	60	8950	8400	7600	7100	9650	9200	8500	8000
270x85	10	12000	12000	11200	10200	12000	12000	12000	11650
	20	11950	11500	10750	10150	12000	11650	11100	10650
	40	10750	10150	9300	8700	11100	10650	9950	9450
	60	9900	9300	8450	7850	10450	9950	9250	8700
300x85	10	12000	12000	12000	11350	12000	12000	12000	12000
	20	12000	12000	11800	11150	12000	12000	11850	11400
	40	11800	11150	10200	9550	11850	11400	10700	10150
	60	10850	10200	9250	8600	11200	10700	9950	9400
330x85	10	12000	12000	12000	12000	12000	12000	12000	12000
	20	12000	12000	12000	12000	12000	12000	12000	12000
	40	12000	12000	11150	10400	12000	12000	11400	10850
	60	11850	11150	10100	9400	11900	11400	10600	10050
360x85	10	12000	12000	12000	12000	12000	12000	12000	12000
	20	12000	12000	12000	12000	12000	12000	12000	12000
	40	12000	12000	12000	11300	12000	12000	12000	11500
	60	12000	12000	10950	10200	12000	12000	11250	10650
390x85	10	12000	12000	12000	12000	12000	12000	12000	12000
	20	12000	12000	12000	12000	12000	12000	12000	12000
	40	12000	12000	12000	12000	12000	12000	12000	12000
	60	12000	12000	11850	11000	12000	12000	11900	11250
420x85	10	12000	12000	12000	12000	12000	12000	12000	12000
	20	12000	12000	12000	12000	12000	12000	12000	12000
	40	12000	12000	12000	12000	12000	12000	12000	12000
	60	12000	12000	12000	11800	12000	12000	12000	11850
450x85	10	12000	12000	12000	12000	12000	12000	12000	12000
	20	12000	12000	12000	12000	12000	12000	12000	12000
	40	12000	12000	12000	12000	12000	12000	12000	12000
	60	12000	12000	12000	12000	12000	12000	12000	12000
480x85	10	12000	12000	12000	12000	12000	12000	12000	12000
	20	12000	12000	12000	12000	12000	12000	12000	12000
	40	12000	12000	12000	12000	12000	12000	12000	12000
	60	12000	12000	12000	12000	12000	12000	12000	12000
510x85	10	12000	12000	12000	12000	12000	12000	12000	12000
	20	12000	12000	12000	12000	12000	12000	12000	12000
	40	12000	12000	12000	12000	12000	12000	12000	12000
	60	12000	12000	12000	12000	12000	12000	12000	12000

NOTES:

1. D = member depth, B = member breadth, NS = not suitable.
2. The above table was based on a batten spacing of 900 mm
3. Maximum birds mouth depth = 30 % of rafter depth
4. End bearing lengths = 35 mm at end supports and 35 mm at internal supports for continuous members. Subscript values Indicate the minimum additional bearing length where required to be greater than 35 mm at end supports and 35 mm at internal supports
5. Construction loads shall not be applied to overhangs until a 190x19 (minimum) timber fascia or other fascia of equivalent stiffness is rigidly and permanently attached to the end of rafter overhangs
6. Rafter spacing up to 1200 mm
7. Not all sizes of SmartLam GL18 in this table are stocked in each state. Please check with your supplier before ordering

SINGLE/CONTINUOUS SPAN ROOF RAFTER AS 4055 CLASSIFICATION C1, C2 AND C3 WITHOUT CEILING ATTACHED

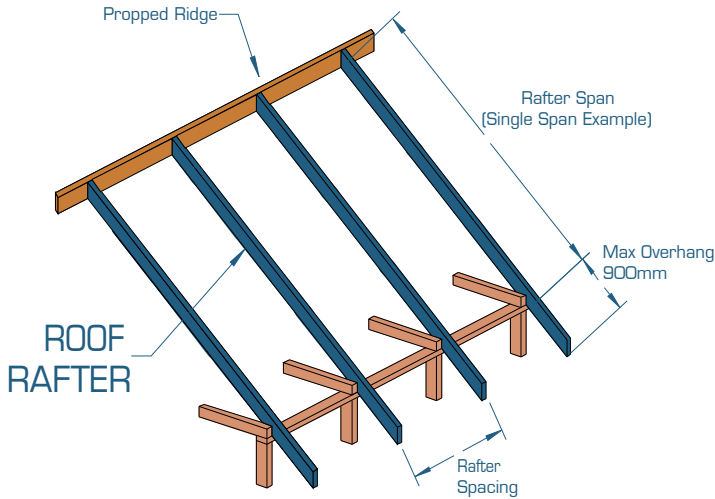

EXAMPLE:

wind speed = C3
 sheet roof - 40 kg/m²
 rafter/truss spacing = 600 mm
 rafter span = 5000 mm
 Enter span table at rafter spacing of 600 mm, and read down to a span equal to or greater than 5000 mm

ADOPT:

SmartLam GL18 - 150 x 65

Note: Not all sizes of SmartLam GL18 in this table are stocked in each state. Please check with your supplier before ordering.

Roof load width (mm)		450	600	900	1200	450	600	900	1200
Member size DxB (mm)	Roof mass (kg/m ²)	Maximum Rafter span (mm)							
		Single span				Continuous span			
150x65	10	6300	5750	4950	4150	7200	6200	4950	4150
	20	6300	5750	5000	4200	7300	6250	5000	4200
	40	6250	5750	5000	4300	7200	6350	5050	4300
	60	5600	5150	4550	4150	6650	6300	5150	4350
180x65	10	7600	6900	5950	5050	8700	7450	5950	5050
	20	7600	6900	6000	5100	8750	7500	6000	5100
	40	7250	6800	6000	5200	8150	7650	6150	5200
	60	6600	6200	5500	5000	7550	7150	6250	5300
210x65	10	8850	8050	7000	5950	10200	8750	7000	5950
	20	8850	8050	7000	6000	10000	8800	7050	6000
	40	8200	7700	7000	6150	9050	8600	7200	6150
	60	7500	7000	6350	5900	8400	7950	7300	6250
240x65	10	10100	9200	8000	6850	11600	10000	8050	6850
	20	10100	9200	8000	6900	10850	10100	8100	6900
	40	9200	8650	7850	7050	9850	9400	8300	7050
	60	8400	7850	7100	6600	9200	8750	8050	7200
270x65	10	11350	10350	9000	7750	12000	11300	9100	7750
	20	11350	10350	9000	7850	11650	11300	9200	7850
	40	10200	9600	8700	8000	10650	10200	9350	8000
	60	9350	8700	7900	7300	10000	9500	8750	8150
300x65	10	12000	11500	10050	8650	12000	12000	10150	8650
	20	12000	11500	10050	8750	12000	12000	10250	8750
	40	11200	10550	9600	8900	11400	10950	10200	8900
	60	10250	9600	8650	8050	10700	10200	9400	8900
330x65	10	12000	12000	11050	9500	12000	12000	11100	9500
	20	12000	12000	11050	9550	12000	12000	11200	9550
	40	12000	11500	10450	9750	12000	11650	10850	9750
	60	11200	10450	9450	8750	11400	10850	10050	9500
360x65	10	12000	12000	12000	10300	12000	12000	12000	10300
	20	12000	12000	12000	10400	12000	12000	12000	10400
	40	12000	12000	11350	10550	12000	12000	11550	10600
	60	12000	11350	10250	9500	12000	11550	10700	10100
390x65	10	12000	12000	12000	11100	12000	12000	12000	11100
	20	12000	12000	12000	11200	12000	12000	12000	11200
	40	12000	12000	12000	11400	12000	12000	12000	11450
	60	12000	12000	11050	10200	12000	12000	11300	10700
420x65	10	12000	12000	12000	11950	12000	12000	12000	11950
	20	12000	12000	12000	12000	12000	12000	12000	12000
	40	12000	12000	12000	12000	12000	12000	12000	12000
	60	12000	12000	11850	10950	12000	12000	11900	11250
450x65	10	12000	12000	12000	12000	12000	12000	12000	12000
	20	12000	12000	12000	12000	12000	12000	12000	12000
	40	12000	12000	12000	12000	12000	12000	12000	12000
	60	12000	12000	12000	11750	12000	12000	12000	11800
480x65	10	12000	12000	12000	12000	12000	12000	12000	12000
	20	12000	12000	12000	12000	12000	12000	12000	12000
	40	12000	12000	12000	12000	12000	12000	12000	12000
	60	12000	12000	12000	12000	12000	12000	12000	12000
510x65	10	12000	12000	12000	12000	12000	12000	12000	12000
	20	12000	12000	12000	12000	12000	12000	12000	12000
	40	12000	12000	12000	12000	12000	12000	12000	12000
	60	12000	12000	12000	12000	12000	12000	12000	12000

SINGLE/CONTINUOUS SPAN ROOF RAFTER AS 4055 CLASSIFICATION C1, C2 AND C3 WITHOUT CEILING ATTACHED [Cont'd]

Roof load width (mm)		450	600	900	1200	450	600	900	1200
Member size DxB (mm)	Roof mass (kg/m ²)	Maximum Rafter span (mm)							
		Single span				Continuous span			
150x85	10	6900	6300	5500	4800	8300	7100	5700	4800
	20	6900	6300	5500	4850	8350	7150	5750	4850
	40	6600	6200	5500	4950	7550	7200	5850	4950
	60	6050	5600	4950	4500	7000	6650	5950	5050
180x85	10	8300	7550	6600	5850	10000	8550	6850	5850
	20	8300	7550	6600	5900	9400	8650	6950	5900
	40	7650	7200	6600	6000	8500	8100	7050	6000
	60	7000	6600	5950	5450	7950	7550	6950	6100
210x85	10	9650	8800	7700	6850	10950	10050	8050	6850
	20	9650	8800	7700	6950	10300	9950	8150	6950
	40	8650	8200	7500	6950	9450	9000	8300	7050
	60	8000	7500	6800	6350	8850	8400	7750	7200
240x85	10	11050	10050	8750	7900	11800	11550	9250	7900
	20	10850	10050	8750	7950	11150	10850	9350	7950
	40	9700	9150	8400	7850	10300	9850	9200	8100
	60	8950	8400	7600	7100	9650	9200	8500	8000
270x85	10	12000	11300	9850	8950	12000	12000	10450	8950
	20	11950	11300	9850	8950	12000	11650	10550	9000
	40	10750	10150	9300	8700	11100	10650	9950	9200
	60	9900	9300	8450	7850	10450	9950	9250	8700
300x85	10	12000	12000	10950	9950	12000	12000	11650	9950
	20	12000	12000	10950	9950	12000	12000	11800	10050
	40	11800	11150	10200	9550	11850	11400	10700	10150
	60	10850	10200	9250	8600	11200	10700	9950	9400
330x85	10	12000	12000	12000	10900	12000	12000	12000	10900
	20	12000	12000	12000	10950	12000	12000	12000	11000
	40	12000	12000	11150	10400	12000	12000	11400	10850
	60	11850	11150	10100	9400	11900	11400	10600	10050
360x85	10	12000	12000	12000	11850	12000	12000	12000	11850
	20	12000	12000	12000	11950	12000	12000	12000	11950
	40	12000	12000	12000	11300	12000	12000	12000	11500
	60	12000	12000	10950	10200	12000	12000	11250	10650
390x85	10	12000	12000	12000	12000	12000	12000	12000	12000
	20	12000	12000	12000	12000	12000	12000	12000	12000
	40	12000	12000	12000	12000	12000	12000	12000	12000
	60	12000	12000	11850	11000	12000	12000	11900	11250
420x85	10	12000	12000	12000	12000	12000	12000	12000	12000
	20	12000	12000	12000	12000	12000	12000	12000	12000
	40	12000	12000	12000	12000	12000	12000	12000	12000
	60	12000	12000	12000	11800	12000	12000	12000	11850
450x85	10	12000	12000	12000	12000	12000	12000	12000	12000
	20	12000	12000	12000	12000	12000	12000	12000	12000
	40	12000	12000	12000	12000	12000	12000	12000	12000
	60	12000	12000	12000	12000	12000	12000	12000	12000
480x85	10	12000	12000	12000	12000	12000	12000	12000	12000
	20	12000	12000	12000	12000	12000	12000	12000	12000
	40	12000	12000	12000	12000	12000	12000	12000	12000
	60	12000	12000	12000	12000	12000	12000	12000	12000
510x85	10	12000	12000	12000	12000	12000	12000	12000	12000
	20	12000	12000	12000	12000	12000	12000	12000	12000
	40	12000	12000	12000	12000	12000	12000	12000	12000
	60	12000	12000	12000	12000	12000	12000	12000	12000

NOTES:

1. D = member depth, B = member breadth, NS = not suitable.
2. The above table was based on a batten spacing of 900 mm
3. Maximum birds mouth depth = 30 % of rafter depth
4. End bearing lengths = 35 mm at end supports and 35 mm at internal supports for continuous members. Subscript values Indicate the minimum additional bearing length where required to be greater than 35 mm at end supports and 35 mm at internal supports
5. Construction loads shall not be applied to overhangs until a 190x19 (minimum) timber fascia or other fascia of equivalent stiffness is rigidly and permanently attached to the end of rafter overhangs
6. Rafter spacing up to 1200 mm
7. Not all sizes of SmartLam GL18 in this table are stocked in each state. Please check with your supplier before ordering

RIDGE/INTERMEDIATE ROOF BEAM AS 4055 CLASSIFICATION N1, N2 AND N3

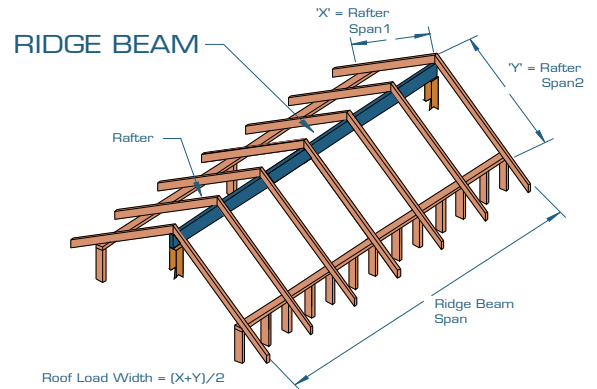
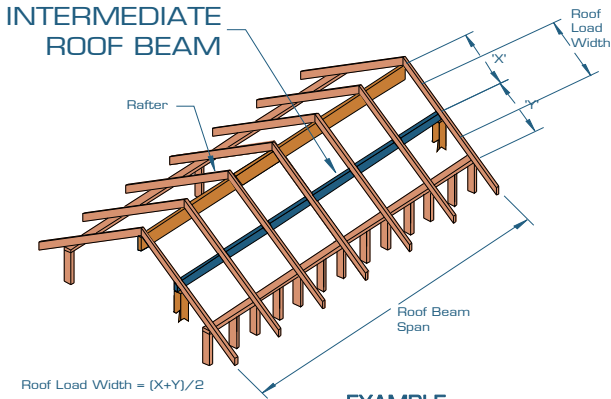

EXAMPLE:

wind speed = N3
 sheet roof - 40 kg/m²
 beam span = 4500 mm
 X = 2000 mm Y = 3000 mm
 roof load width = (X+Y)/2 = 2500 mm

Enter single span table at 3000 roof load width with column
 And read down to span equal to or greater than 4500 mm

ADOPT:

SmartLam GL18 - 210 x 65

Roof load width (mm)		1800	3000	4200	5400	6600	7800	1800	3000	4200	5400	6600	7800
Member size DxB (mm)	Roof mass (kg/m ²)	Maximum Ridge span (mm)											
		Single span						Continuous span					
150x65	40	4000	3300	2900	2650	2400	2250	5050	3950	3350	2950	2650	2450
	75	3300	2750	2400	2200	2050	1900	4200	3550	3100	2700	2450	2200
180x65	40	4850	4050	3550	3200	2900	2700	6050	4750	4050	3550	3200	2900
	75	4000	3300	2950	2650	2450	2300	5050	4250	3700	3250	2900	2650
210x65	40	5700	4750	4150	3750	3450	3200	6750	5550	4700	4150	3700	3400
	75	4700	3900	3450	3150	2900	2700	5850	4950	4300	3800	3400	3100
240x65	40	6450	5450	4800	4300	3950	3700	7450	6400	5400	4750	4250	3900
	75	5400	4500	3950	3600	3300	3100	6500	5650	4900	4300	3900	3550
270x65	40	7150	6100	5450	4900	4500	4150	8100	7100	6050	5300	4800	4350
	75	6100	5100	4500	4100	3750	3500	7100	6250	5500	4850	4350	4000
300x65	40	7850	6750	6050	5500	5000	4650	8700	7700	6750	5900	5300	4850
	75	6700	5700	5050	4550	4200	3950	7650	6750	6150	5400	4850	4450
330x65	40	8550	7300	6600	6050	5550	5150	9350	8250	7350	6450	5800	5300
	75	7300	6250	5600	5050	4650	4350	8200	7250	6650	5900	5300	4850 ₁₀
360x65	40	9250	7900	7100	6550	6100	5700	9900	8800	7950	6950	6250	5750 ₁₀
	75	7850	6750	6100	5550	5100	4800	8750	7700	7050	6350	5750 ₁₀	5250 ₁₅
390x65	40	10000	8500	7650	7000	6550	6150 ₅	10500	9300	8500	7500	6750 ₅	6150 ₁₅
	75	8450	7250	6550	6050	5600	5200 ₅	9250	8200	7500	6850 ₅	6150 ₁₅	5650 ₂₅
420x65	40	10700	9100	8150	7500	6950 ₅	6550 ₅	11050	9800	9000	8000	7200 ₁₅	6600 ₂₀
	75	9050	7750	7000	6450	6050 ₅	5650 ₁₀	9750	8650	7900	7300 ₁₀	6600 ₂₀	6050 ₃₀
450x65	40	11450	9750	8700	7950	7400 ₅	6950 ₁₀	11600	10300	9450	8550 ₁₀	7700 ₂₀	7050 ₃₀
	75	9650	8250	7400	6850	6400 ₅	6050 ₁₀	10250	9100	8350	7800 ₁₅	7000 ₃₀	6400 ₄₀
150x85	40	4400	3650	3200	2900	2650	2450	5500	4550	3850	3400	3050	2800
	75	3600	3000	2650	2400	2250	2100	4600	3850	3400	3100	2800	2550
180x85	40	5300	4400	3850	3500	3200	3000	6400	5450	4650	4050	3650	3350
	75	4350	3650	3200	2900	2700	2500	5500	4600	4100	3700	3350	3050
210x85	40	6200	5200	4550	4100	3750	3500	7150	6300	5400	4750	4250	3900
	75	5150	4300	3800	3450	3150	2950	6250	5350	4800	4300	3900	3550
240x85	40	6950	6000	5250	4750	4350	4050	7850	6950	6150	5400	4850	4450
	75	5950	4950	4350	3950	3650	3400	6900	6100	5450	4950	4450	4050
270x85	40	7650	6600	5950	5350	4950	4600	8550	7550	6900	6050	5450	5000
	75	6550	5600	4950	4500	4150	3850	7550	6650	6100	5550	5000	4550
300x85	40	8400	7250	6500	6000	5500	5100	9200	8150	7500	6750	6050	5550
	75	7200	6200	5550	5000	4650	4300	8150	7200	6600	6150	5550	5050
330x85	40	9200	7900	7100	6500	6100	5700	9850	8750	8000	7350	6600	6050
	75	7850	6750	6100	5550	5150	4800	8700	7700	7050	6600	6050	5550
360x85	40	9950	8550	7650	7050	6550	6200	1050 ₅	9300	8550	7950	7150	6550
	75	8500	7300	6600	6100	5650	5250	9250	8200	7550	7050	6550	6000 ₅
390x85	40	10750	9200	8250	7550	7050	6650	11100	9850	9050	8450	7700	7050
	75	9150	7850	7050	6500	6100	5750	9800	8700	8000	7500	7050	6450 ₁₀
420x85	40	11550	9850	8800	8100	7550	7100	11650	10400	9550	8950	8250	7550 ₁₀
	75	9800	8400	7550	6950	6500	6150	10350	9200	8450	7900	7500 ₁₀	6900 ₁₅
450x85	40	12000	10500	9400	8600	8000	7550 ₅	12000	10900	10050	9400	8750 ₅	8000 ₁₅
	75	10450	8950	8050	7400	6950	6550 ₅	10850	9650	8900	8300	7850 ₁₅	7350 ₂₅

RIDGE/INTERMEDIATE ROOF BEAM AS 4055 CLASSIFICATION C1, C2 AND C3

Roof load width (mm)		1800	3000	4200	5400	6600	7800	1800	3000	4200	5400	6600	7800
Member size DxB (mm)	Roof mass (kg/m ²)	Maximum Ridge span (mm)											
		Single span						Continuous span					
150x65	40	3300	2550	2150	1900	1750	1600	3300	2550	2150	1900	1750	1600
	75	3300	2650	2250	2000	1800	1650	3450	2650	2250	2000	1800	1650
180x65	40	4050	3100	2600	2300	2100	1900	4050	3100	2600	2300	2100	1900
	75	4000	3200	2700	2400	2150	2000	4200	3200	2700	2400	2150	2000
210x65	40	4800	3600	3050	2700	2450	2250	4800	3600	3050	2700	2450	2250
	75	4700	3700	3150	2800	2500	2350	5000	3700	3150	2800	2500	2350
240x65	40	5550	4100	3500	3100	2800	2550	5550	4100	3500	3100	2800	2550
	75	5400	4250	3600	3200	2900	2650	5750	4250	3600	3200	2900	2650
270x65	40	6300	4650	3900	3450	3150	2900	6300	4650	3900	3450	3150	2900
	75	6100	4800	4050	3600	3250	3000	6550	4800	4050	3600	3250	3000
300x65	40	7050	5150	4350	3850	3500	3200	7050	5150	4350	3850	3500	3200
	75	6700	5350	4500	4000	3600	3350 ₅	7350	5350	4500	4000	3600	3350 ₁₀
330x65	40	7750	5650	4750	4200	3800	3500	7750	5650	4750	4200	3800	3500 ₅
	75	7300	5800	4900	4350	3950 ₅	3650 ₅	8050	5800	4900	4350	3950 ₁₀	3650 ₂₀
360x65	40	8450	6100	5150	4550	4150	3800 ₅	8450	6100	5150	4550	4150 ₅	3800 ₁₅
	75	7850	6350	5350	4700	4250 ₅	3950 ₁₀	8750	6350	5350	4700 ₁₀	4250 ₂₀	3950 ₃₀
390x65	40	9150	6650	5550	4900	4450 ₅	4100 ₅	9150	6650	5550	4900	4450 ₁₀	4100 ₃₀
	75	8450	6900	5750	5050 ₅	4600 ₁₀	4250 ₁₅	9250	6900	5750 ₅	5050 ₁₅	4600 ₂₅	4250 ₄₀
420x65	40	9800	7200	5950	5250	4750 ₅	4400 ₁₀	9800	7200	5950	5250 ₁₀	4750 ₂₀	4400 ₃₀
	75	9050	7450	6150 ₅	5450 ₁₀	4900 ₁₀	4550 ₁₅	9750	7450	6150 ₁₀	5450 ₂₅	4900 ₃₅	4550 ₃₀
450x65	40	10500	7700	6350	5600 ₅	5050 ₁₀	4650 ₁₅	10500	7700	6350	5600 ₁₅	5050 ₂₅	4650 ₃₅
	75	9650	8000	6550 ₅	5800 ₁₀	5250 ₁₅	4850 ₂₀	10250	8000	6550 ₁₅	5800 ₃₀	5250 ₄₅	4850 ₃₀
150x85	40	3850	2950	2500	2200	2000	1850	3850	2950	2500	2200	2000	1850
	75	3600	3000	2600	2250	2050	1900	3950	3050	2600	2250	2050	1900
180x85	40	4700	3550	3000	2650	2400	2200	4700	3550	3000	2650	2400	2200
	75	4350	3650	3100	2750	2500	2300	4850	3650	3100	2750	2500	2300
210x85	40	5550	4100	3500	3100	2800	2600	5550	4100	3500	3100	2800	2600
	75	5150	4250	3600	3200	2900	2650	5750	4250	3600	3200	2900	2650
240x85	40	6450	4700	4000	3500	3200	2950	6450	4700	4000	3500	3200	2950
	75	5950	4900	4100	3650	3300	3050	6650	4900	4100	3650	3300	3050
270x85	40	7300	5300	4500	3950	3600	3300	7300	5300	4500	3950	3600	3300
	75	6550	5500	4650	4100	3700	3450	7550	5500	4650	4100	3700	3450
300x85	40	8150	5900	5000	4400	4000	3700	8150	5900	5000	4400	4000	3700
	75	7200	6100	5150	4550	4150	3800	8150	6100	5150	4550	4150	3800
330x85	40	8950	6500	5450	4800	4350	4000	8950	6500	5450	4800	4350	4000
	75	7850	6750	5650	5000	4500	4150	8700	6750	5650	5000	4500	4150 ₁₀
360x85	40	9750	7150	5900	5200	4700	4350	9750	7150	5900	5200	4700	4350
	75	8500	7300	6100	5400	4900	4500 ₅	9250	7400	6100	5400	4900 ₅	4500 ₁₅
390x85	40	10550	7750	6350	5600	5100	4700	10550	7750	6350	5600	5100	4700 ₁₀
	75	9100	7850	6550	5800	5250 ₅	4850 ₁₀	9800	8050	6550	5800 ₅	5250 ₁₅	4850 ₂₅
420x85	40	11300	8350	6800	6000	5450	5000 ₅	11300	8350	6800	6000	5450 ₅	5000 ₁₅
	75	9800	8400	7050	6200 ₅	5650 ₅	5200 ₁₀	10350	8650	7050	6200 ₁₀	5650 ₂₀	5200 ₃₀
450x85	40	12000	8950	7250	6400	5800 ₅	5350 ₅	12000	8950	7250	6400	5800 ₁₀	5350 ₂₀
	75	10450	8950	7500	6600 ₅	6000 ₁₀	5550 ₁₅	10850	9250	7500 ₅	6600 ₁₅	6000 ₂₅	5550 ₄₀

NOTES:

1. D = member depth, B = member breadth, NS = not suitable.
2. End bearing lengths = 35 mm at end supports and 70 mm at internal supports for continuous members. Subscript values indicate the minimum additional bearing length where required to be greater than 35 mm at end supports and 70 mm at internal supports.
3. Rafter spacing up to 1200 mm
4. Not all sizes of SmartLam GL18 in this table are stocked in each state. Please check with your supplier before ordering

SINGLE SPAN VERANDAH BEAM AS 4055 CLASSIFICATION N1, N2 AND N3

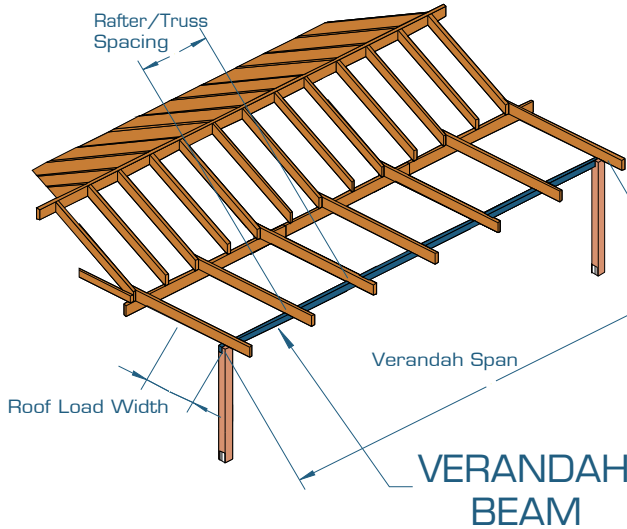

EXAMPLE:

wind speed = N3
 sheet roof - 40 kg/m²
 rafter/truss spacing = 600 mm
 verandah span = 3500 mm (single span)
 roof load width = 3900 mm
 Enter span table at 4500 roof load width column, rafter spacing of 1200 mm, and read down to a span equal to or greater than 3500 mm

ADOPT:

SmartLam GL18 - 210 x 65

Roof load width (mm)		1500		3000		4500		6000		7500	
Rafter/truss spacing (mm)		600	1200	600	1200	600	1200	600	1200	600	1200
Member size DxB (mm)	Roof mass (kg/m ²)	Maximum Verandah beam span (mm)									
		Single span									
150x65	40	4000	4000	3200	3100	2700	2800	2500	2500	2300	2200
	75	3200	3200	2600	2600	2200	2200	2000	2000	1800	1800
180x65	40	4700	4700	3900	3800	3400	3300	3000	3000	2700	2700
	75	3900	3900	3100	3100	2700	2700	2400	2400	2200	2200
210x65	40	5300	5300	4400	4400	4000	3900	3600	3500	3200	3100
	75	4500	4500	3700	3600	3200	3100	2900	2900	2600	2700
240x65	40	6000	6000	5000	5000	4400	4400	4100	4100	3700	3600
	75	5100	5100	4200	4200	3700	3600	3300	3300	3100	3000
270x65	40	6700	6700	5500	5500	4900	4900	4600	4500	4200	4100
	75	5600	5600	4600	4600	4100	4100	3800	3700	3500	3400
300x65	40	7400	7400	6100	6100	5400	5400	5000	5000	4700	4700
	75	6200	6200	5100	5100	4500	4500	4200	4200	3900	3900
330x65	40	8200	8200	6700	6700	5900	5900	5400	5400	5100	5100
	75	6800	6800	5500	5500	4900	4900	4500	4500	4200	4200
360x65	40	8900	8900	7300	7200	6400	6400	5900	5900	5500	5500
	75	7400	7400	6000	6000	5300	5300	4900	4900	4600	4600
390x65	40	9700	9700	7900	7900	7000	6900	6400	6300	6000	5900
	75	8000	8000	6500	6500	5700	5700	5300	5300	4900	4900
420x65	40	10500	10500	8500	8500	7500	7500	6800	6800	6400	6300
	75	8700	8600	7000	7000	6200	6100	5600	5600	5300	5300
450x65	40	11300	11300	9100	9100	8000	8000	7300	7300	6800	6800
	75	9300	9300	7500	7500	6600	6600	6000	6000	5600	5600 _s
480x65	40	12000	12000	9800	9700	8600	8500	7800	7800	7300	7200
	75	10000	9900	8000	8000	7000	7000	6400	6400	6000	5900 _s
510x65	40	12000	12000	10400	10400	9100	9100	8300	8300	7700	7600
	75	10600	10600	8500	8500	7400	7400	6800	6800 _s	6300 _s	6300 _s
150x85	40	4300	4300	3500	3400	3000	3000	2700	2800	2500	2600
	75	3600	3500	2800	2800	2400	2500	2200	2200	2000	2000
180x85	40	5000	5000	4200	4200	3700	3600	3300	3300	3100	3000
	75	4200	4200	3400	3400	2900	2900	2700	2700	2500	2500
210x85	40	5700	5700	4800	4800	4300	4300	3900	3900	3600	3600
	75	4800	4900	4000	4000	3500	3400	3100	3100	2900	2900
240x85	40	6500	6500	5400	5400	4800	4800	4400	4400	4100	4100
	75	5500	5500	4500	4500	4000	4000	3600	3600	3400	3300
270x85	40	7200	7200	6000	6000	5300	5300	4900	4900	4600	4600
	75	6100	6100	5000	5000	4500	4400	4100	4100	3800	3800
300x85	40	8000	8000	6600	6600	5900	5800	5400	5400	5100	5100
	75	6700	6700	5500	5500	4900	4900	4500	4500	4200	4200
330x85	40	8800	8800	7200	7200	6400	6400	5900	5900	5500	5500
	75	7400	7400	6000	6000	5300	5300	4900	4900	4600	4600
360x85	40	9600	9600	7900	7900	7000	7000	6400	6400	6000	6000
	75	8000	8000	6500	6500	5800	5700	5300	5300	5000	4900
390x85	40	10400	10400	8500	8500	7500	7500	6900	6900	6400	6400
	75	8700	8700	7100	7000	6200	6200	5700	5700	5300	5300
420x85	40	11300	11300	9200	9200	8100	8100	7400	7400	6900	6900
	75	9400	9400	7600	7600	6700	6700	6100	6100	5700	5700
450x85	40	12000	12000	9900	9900	8700	8700	8000	8000	7400	7400
	75	10100	10100	8100	8100	7200	7100	6500	6500	6100	6100
480x85	40	12000	12000	10600	10600	9300	9300	8500	8500	7900	7900
	75	10800	10800	8700	8700	7600	7600	7000	7000	6500	6500
510x85	40	12000	12000	11400	11300	10000	9900	9100	9100	8400	8400
	75	11600	11600	9300	9300	8100	8100	7400	7400	6900	6900 _s
540x85	40	9200	9300	12000	12000	10600	10600	9700	9600	9000	9000
	75	12000	12000	9900	9800	8600	8600	7800	7800	7300 _s	7300 _s
570x85	40	8300	8400	12000	12000	11300	11200	10200	10200	9500	9500
	75	12000	12000	10400	10400	9100	9100	8300	8300	7700 _s	7700 _s

CONTINUOUS SPAN VERANDAH BEAM AS 4055 CLASSIFICATION N1, N2 AND N3

Roof load width (mm)		1500		3000		4500		6000		7500	
Rafter/truss spacing (mm)		600	1200	600	1200	600	1200	600	1200	600	1200
Member size DxB (mm)	Roof mass (kg/m ²)	Maximum Verandah beam span (mm)									
		Continuous span									
150x65	40	4600	4600	3700	3600	3000	3000	2600	2700	2300	2300
	75	4000	4000	3200	3200	2800	2800	2600	2600	2400	2400
180x65	40	5300	5300	4500	4400	3600	3500	3100	3100	2800	2800
	75	4600	4600	3900	3900	3400	3300	3100	3100	2900	2900
210x65	40	5900	5900	5100	5100	4200	4200	3600	3600	3300	3200
	75	5100	5200	4400	4300	4000	3900	3600	3600	3300	3300
240x65	40	6500	6500	5600	5600	4800	4800	4200	4200	3700	3700
	75	5700	5700	4800	4800	4400	4300	4100	4000	3800	3800
270x65	40	7000	7100	6100	6100	5500	5500	4700	4700	4200	4200
	75	6200	6200	5300	5300	4800	4800	4400	4400	4200	4200
300x65	40	7400	7700	6500	6600	6000	6000	5300	5300	4700	4600
	75	6600	6700	5700	5700	5200	5200	4800	4800	4600	4600
330x65	40	7800	8200	6900	7000	6400	6400	5700	5700	5100	5200
	75	7000	7200	6100	6100	5600	5600	5200	5200	4900	4900
360x65	40	8200	8700	7300	7500	6800	6800	6200	6200	5600	5500
	75	7400	7600	6500	6500	5900	5900	5500	5500	5200	5200
390x65	40	8600	9200	7700	8000	7100	7300	6700	6700	6000	5900
	75	7800	8100	6800	6900	6300	6300	5900	5900	5500	5500
420x65	40	9000	9700	8000	8400	7400	7700	7100	7100	6400	6400
	75	8100	8500	7200	7300	6600	6600	6200	6200	5900 ₅	5900
450x65	40	9400	10200	8300	8800	7800	8100	7400	7500	6800	6800
	75	8400	8900	7500	7700	6900	7000	6500	6500	6200 ₁₀	6200
480x65	40	9800	10600	8700	9200	8100	8500	7700	7900	7300	7200
	75	8800	9400	7700	8000	7200	7300	6800	6800	6500 ₁₅	6500
510x65	40	10200	11100	9000	9700	8400	8900	7900	8300	7600	7700
	75	9100	9800	8000	8400	7500	7600	7100 ₅	7100 ₅	6800 ₂₀	6800
150x85	40	4900	5000	4200	4200	3400	3400	3000	3000	2700	2700
	75	4300	4300	3500	3500	3100	3100	2800	2800	2600	2600
180x85	40	5600	5600	4800	4800	4100	4100	3600	3500	3200	3200
	75	4900	4900	4200	4200	3700	3700	3400	3300	3100	3100
210x85	40	6300	6300	5400	5400	4900	4900	4200	4200	3700	3700
	75	5500	5500	4700	4600	4200	4200	3900	3900	3600	3600
240x85	40	6800	6900	6000	6000	5400	5400	4800	4800	4300	4300
	75	6000	6000	5100	5200	4700	4600	4400	4300	4100	4100
270x85	40	7300	7500	6500	6500	5900	5900	5400	5400	4800	4800
	75	6500	6600	5600	5600	5100	5100	4800	4700	4500	4500
300x85	40	7800	8100	6900	7000	6400	6400	6000	6000	5400	5400
	75	7000	7100	6100	6100	5500	5500	5100	5200	4900	4900
330x85	40	8200	8600	7300	7500	6800	6800	6400	6400	5900	5800
	75	7400	7600	6500	6500	5900	5900	5500	5500	5200	5200
360x85	40	8600	9200	7700	8000	7100	7300	6800	6800	6400	6400
	75	7800	8100	6800	6900	6300	6300	5900	5900	5600	5600
390x85	40	9000	9700	8000	8500	7500	7700	7100	7200	6800	6900
	75	8100	8600	7200	7300	6700	6700	6300	6300	5900	5900
420x85	40	9400	10200	8400	8900	7800	8200	7400	7600	7100	7300
	75	8500	9000	7500	7700	7000	7000	6600	6600	6300	6300
450x85	40	9800	10700	8700	9300	8100	8600	7700	8000	7400	7600
	75	8800	9500	7800	8200	7300	7400	6900	6900	6600	6600
480x85	40	10300	11200	9100	9800	8500	9000	8000	8500	7700	8000
	75	9200	9900	8100	8600	7600	7800	7200	7300	6900	6900
510x85	40	10700	11600	9400	10200	8800	9400	8300	8800	8000	8400
	75	9500	10300	8400	8900	7800	8100	7400	7600	7100	7200
540x85	40	11100	12000	9800	10600	9100	9800	8600	9200	8300	8700
	75	9900	10800	8700	9300	8100	8500	7700	7900	7400 ₅	7500 ₅
570x85	40	11400	12000	10100	11000	9400	10200	8900	9600	8500	9100
	75	10200	11200	9000	9700	8400	8800	7900	8300	7600 ₅	7800 ₁₀

NOTES:

1. D = member depth, B = member breadth, NS = not suitable.
2. End bearing lengths = 35 mm at end supports and 70 mm at internal supports for continuous members. Subscript values indicate the minimum additional bearing length where required to be greater than 35 mm at end supports and 70 mm at internal supports.
3. Restraint value for slenderness calculations is 1200 mm
4. Not all sizes of SmartLam GL18 in this table are stocked in each state. Please check with your supplier before ordering

SINGLE SPAN VERANDAH BEAM AS 4055 CLASSIFICATION C1, C2 AND C3

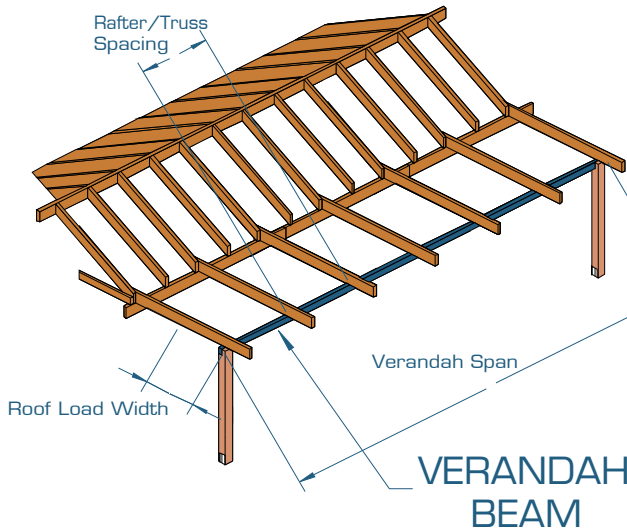

EXAMPLE:

wind speed = C3
 sheet roof - 40 kg/m²
 rafter/truss spacing = 600 mm
 verandah span = 3500 mm (single span)
 roof load width = 3900 mm
 Enter span table at 4500 roof load width column, rafter spacing of 1200 mm, and read down to a span equal to or greater than 3500 mm

ADOPT:

SmartLam GL18 - 240 x 65

Roof load width (mm)		1500		3000		4500		6000		7500	
Rafter/truss spacing (mm)		600	1200	600	1200	600	1200	600	1200	600	1200
Member size DxB (mm)	Roof mass (kg/m ²)	Maximum Verandah span (mm)									
		Single span									
150x65	40	4000	4000	2900	2800	2400	2300	2000	1800	1800	1500
	75	3200	3200	2600	2600	2200	2200	2000	2000	1800	1600
180x65	40	4700	4700	3600	3400	2900	2800	2500	2400	2200	2100
	75	3900	3900	3100	3100	2700	2700	2400	2400	2200	2200
210x65	40	5300	5300	4100	4000	3400	3200	2900	2800	2600	2500
	75	4500	4500	3700	3600	3200	3100	2900	2900	2600	2600
240x65	40	6000	6000	4800	4700	3900	3700	3300	3200	2900	2900
	75	5100	5100	4200	4200	3700	3600	3300	3300	3100	3000
270x65	40	6700	6700	5400	5300	4400	4300	3800	3600	3400	3200
	75	5600	5600	4600	4600	4100	4100	3800	3700	3500	3300
300x65	40	7400	7400	6000	5900	4900	4800	4200	4100	3800	3600
	75	6200	6200	5100	5100	4500	4500	4200	4200	3900	3800
330x65	40	8200	8200	6500	6500	5300	5300	4600	4600	4100	4000
	75	6800	6800	5500	5500	4900	4900	4500	4500	4200	4200
360x65	40	8900	8900	7100	7100	5800	5700	5000	5000	4400	4400
	75	7400	7400	6000	6000	5300	5300	4900	4900	4600	4600
390x65	40	9700	9700	7600	7600	6200	6100	5400	5300	4800	4800
	75	8000	8000	6500	6500	5700	5700	5300	5300	4900	4900 ₅
420x65	40	10500	10500	8200	8100	6600	6600	5700	5700	5100	5100
	75	8700	8600	7000	7000	6200	6100	5600	5600	5300	5300 ₅
450x65	40	11300	11300	8700	8600	7100	7100	6100	6000	5500	5400
	75	9300	9300	7500	7500	6600	6600	6000	6000	5600 ₅	5600 ₁₀
480x65	40	12000	12000	9200	9200	7500	7500	6500	6400	5800	5700
	75	10000	9900	8000	8000	7000	7000	6400	6400	6000 ₅	5900 ₅
510x65	40	12000	12000	9800	9800	8000	7900	6900	6800	6200	6000
	75	10600	10600	8500	8500	7400	7400	6800 ₅	6800 ₅	6300 ₁₀	6300 ₅
150x85	40	4300	4300	3400	3200	2700	2700	2400	2200	2100	1900
	75	3500	3500	2800	2800	2400	2500	2200	2200	2000	2000
180x85	40	5000	5000	4100	3900	3300	3100	2800	2700	2500	2400
	75	4200	4200	3400	3400	2900	2900	2700	2700	2500	2500
210x85	40	5700	5700	4800	4700	3900	3700	3300	3200	2900	2900
	75	4800	4900	4000	4000	3500	3400	3100	3100	2900	2900
240x85	40	6500	6500	5400	5400	4400	4400	3800	3700	3400	3200
	75	5500	5500	4500	4500	4000	4000	3600	3600	3400	3300
270x85	40	7200	7200	6000	6000	5000	5000	4300	4200	3900	3700
	75	6100	6100	5000	5000	4500	4400	4100	4100	3800	3800
300x85	40	8000	8000	6600	6600	5600	5500	4800	4800	4300	4200
	75	6700	6700	5500	5500	4900	4900	4500	4500	4200	4200
330x85	40	8800	8800	7200	7200	6100	6000	5300	5200	4700	4700
	75	7400	7400	6000	6000	5300	5300	4900	4900	4600	4600
360x85	40	9600	9600	7900	7900	6600	6500	5700	5600	5100	5100
	75	8000	8000	6500	6500	5800	5700	5300	5300	5000	4900
390x85	40	10500	10400	8500	8500	7100	7100	6200	6000	5500	5400
	75	8700	8700	7100	7000	6200	6200	5700	5700	5300	5300
420x85	40	11300	11300	9200	9200	7600	7600	6600	6500	5900	5800
	75	9400	9400	7600	7600	6700	6700	6100	6100	5700	5700
450x85	40	12000	12000	9900	9900	8100	8100	7000	7000	6300	6200
	75	10100	10100	8100	8100	7200	7100	6500	6500	6100	6100
480x85	40	12000	12000	10600	10600	8600	8600	7500	7400	6600	6600
	75	10900	10800	8700	8700	7600	7600	7000	7000	6500	6500
510x85	40	12000	12000	11200	11200	9100	9100	7900	7800	7000	7000
	75	11600	11600	9300	9300	8100	8100	7400	7400	6900	6900 ₅
540x85	40	9200	9300	11800	11800	9600	9600	8300	8200	7400	7400
	75	12000	12000	9900	9800	8600	8600	7800	7800	7300 ₅	7300 ₁₀
570x85	40	8300	8400	12000	12000	10100	10100	8700	8700	7800	7700
	75	12000	12000	10400	10400	9100	9100	8300	8300	7700 ₅	7700 ₁₀

CONTINUOUS SPAN VERANDAH BEAM AS 4055 CLASSIFICATION C1, C2 AND C3

Roof load width (mm)		1500		3000		4500		6000		7500	
Rafter/truss spacing (mm)		600	1200	600	1200	600	1200	600	1200	600	1200
Member size DxB (mm)	Roof mass (kg/m ²)	Maximum Verandah beam span (mm)									
		Continuous span									
150x65	40	4200	4200	2900	2900	2400	2500	2100	2000	1800	1600
	75	4000	4000	3100	3100	2500	2600	2200	2100	1900	1900
180x65	40	5100	5100	3600	3500	2900	2900	2500	2600	2200	2100
	75	4600	4600	3800	3700	3000	3000	2600	2700	2300	2300
210x65	40	5900	5900	4200	4200	3400	3300	2900	2900	2600	2700
	75	5100	5200	4400	4300	3500	3500	3100	3000	2700	2800
240x65	40	6500	6500	4800	4800	3900	3800	3400	3300	3000	3000
	75	5700	5700	4800	4800	4100	4100	3500	3400	3100	3100
270x65	40	7000	7100	5400	5400	4400	4400	3800	3700	3400	3300
	75	6200	6200	5300	5300	4600	4500	4000	4000	3500	3500
300x65	40	7400	7700	6000	5900	4900	4900	4200	4200	3800	3700
	75	6600	6700	5700	5700	5100	5100	4400	4400	3900	3900
330x65	40	7800	8200	6500	6500	5300	5300	4600	4600	4100	4100
	75	7000	7200	6100	6100	5600	5600	4800	4800	4300	4300
360x65	40	8200	8700	7100	7100	5800	5700	5000	5000	4500	4500
	75	7400	7600	6500	6500	5900	5900	5200	5200	4700	4600
390x65	40	8600	9200	7600	7600	6200	6200	5400	5400	4800	4700
	75	7800	8100	6800	6900	6300	6300	5600	5600	5000	5000
420x65	40	9000	9700	8000	8200	6700	6700	5800	5700	5100	5100
	75	8100	8500	7200	7300	6600	6600	6100	6000	5400 ₅	5400 ₅
450x65	40	9400	10200	8300	8700	7100	7100	6100	6100	5500	5500
	75	8400	8900	7500	7700	6900	7000	6400	6400	5700 ₁₀	5700 ₁₀
480x65	40	9800	10600	8700	9200	7500	7500	6500	6500	5800	5800
	75	8800	9400	7700	8000	7200	7300	6800 ₅	6800 ₅	6100 ₁₅	6000 ₁₅
510x65	40	10200	11100	9000	9700	8000	8000	6900	6900	6200	6100
	75	9100	9800	8000	8400	7500	7600	7100 ₁₀	7100 ₁₀	6400 ₂₀	6400 ₂₀
150x85	40	4900	4900	3400	3300	2800	2800	2400	2500	2100	2000
	75	4300	4300	3500	3500	2900	2900	2500	2600	2200	2100
180x85	40	5600	5600	4100	4100	3300	3300	2900	2900	2600	2600
	75	4900	4900	4200	4200	3500	3400	3000	3000	2700	2700
210x85	40	6300	6300	4800	4800	3900	3900	3400	3300	3000	3000
	75	5500	5500	4700	4600	4100	4100	3500	3400	3100	3100
240x85	40	6800	6900	5500	5500	4500	4400	3900	3800	3500	3400
	75	6000	6000	5100	5200	4700	4600	4000	4000	3600	3500
270x85	40	7300	7500	6200	6100	5000	5100	4300	4300	3900	3800
	75	6500	6600	5600	5600	5100	5100	4600	4500	4000	4000
300x85	40	7800	8100	6900	6800	5600	5600	4800	4800	4300	4300
	75	7000	7100	6100	6100	5500	5500	5100	5100	4500	4500
330x85	40	8200	8600	7300	7500	6100	6100	5300	5300	4700	4700
	75	7400	7600	6500	6500	5900	5900	5500	5500	4900	4900
360x85	40	8600	9200	7700	8000	6600	6600	5700	5700	5100	5100
	75	7800	8100	6800	6900	6300	6300	5900	5900	5300	5300
390x85	40	9000	9700	8000	8500	7100	7100	6200	6100	5500	5500
	75	8100	8600	7200	7300	6700	6700	6300	6300	5800	5700
420x85	40	9400	10200	8400	8900	7600	7600	6600	6600	5900	5800
	75	8500	9000	7500	7700	7000	7000	6600	6600	6200	6100
450x85	40	9900	10700	8700	9300	8100	8100	7000	7000	6300	6300
	75	8800	9500	7800	8200	7300	7400	6900	6900	6600	6600
480x85	40	10300	11200	9100	9800	8500	8600	7500	7400	6700	6700
	75	9200	9900	8100	8600	7600	7800	7200	7300	6900	6900
510x85	40	10700	11600	9400	10200	8800	9100	7900	7900	7100	7000
	75	9500	10300	8400	8900	7800	8100	7400	7600	7100 ₅	7200 ₁₀
540x85	40	11100	12000	9800	10600	9100	9600	8300	8300	7400	7400
	75	9900	10800	8700	9300	8100	8500	7700	7900	7400 ₁₀	7500 ₁₀
570x85	40	11400	12000	10100	11000	9400	10100	8700	8700	7800	7800
	75	10200	11200	9000	9700	8400	8800	7900	8300	7600 ₁₀	7800 ₁₅

NOTES:

1. D = member depth, B = member breadth, NS = not suitable.
2. End bearing lengths = 35 mm at end supports and 70 mm at internal supports for continuous members. Subscript values indicate the minimum additional bearing length where required to be greater than 35 mm at end supports and 70 mm at internal supports.
3. Restraint value for slenderness calculations is 1200 mm
4. Not all sizes of SmartLam GL18 in this table are stocked in each state. Please check with your supplier before ordering

HIP RAFTER—SHEET AND TILE ROOF AS 4055 WIND CLASSIFICATION N1, N2, N3, C1, C2 & C3

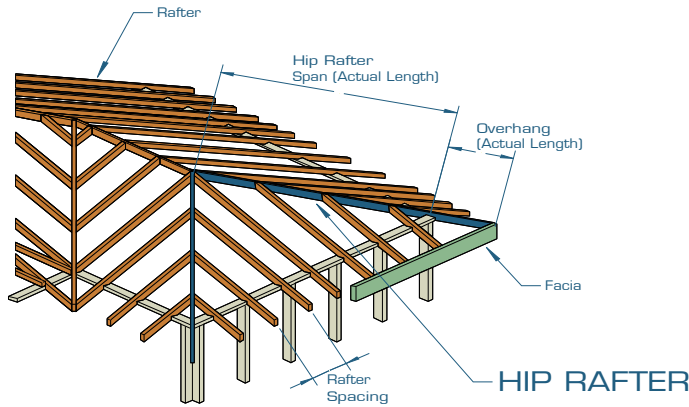

EXAMPLE:

wind speed = N3
 roof load = 40 kg/m² (sheet roof)
 hip rafter span = 4500 mm (single span)
 rafter spacing = 600 mm

Enter column at (N1, N2 & N3) wind speed, 600 mm rafter spacing and read down to span equal to or greater than 4500 mm for a 40 kg/m² roof load

ADOPT:

SmartLam GL18 — 240x65

Wind Speed		N1, N2 & N3				C1, C2 & C3			
Rafter spacing (mm)		600		1200		600		1200	
		Maximum Rafter span + overhang span (mm)							
Member size DxB (mm)	Roof & ceiling mass (kg/m ²)	Span		Overhang		Span		Overhang	
		Single span				Single span			
150x65	40	3650	725	3650	625	3350	650	3350	475
	75	3350	650	3350	650	3350	650	3350	500
180x65	40	4050	800	4050	725	3750	750	3750	550
	75	3700	700	3700	700	3700	700	3700	575
210x65	40	4450	850	4450	825	4100	800	4100	625
	75	4100	800	4100	800	4100	800	4100	650
240x65	40	4800	950	4800	925	4450	850	4450	700
	75	4400	875	4400	875	4400	875	4400	725
270x65	40	5200	1000	5200	1025	4800	950	4800	775
	75	4750	950	4750	950	4750	950	4750	800
300x65	40	5500	1100	5500	1100	5100	1000	5100	850
	75	5050	1000	5050	1000	5050	1000	5050	875
330x65	40	5850	1150	5850	1150	5400	1075	5400	925
	75	5350	1050	5350	1050	5350	1050	5350	925
360x65	40	6150	1225	6150	1225	5700	1100	5700	975
	75	5600	1100	5600	1100	5600	1100	5600	1000
390x65	40	6450	1250	6450	1250	5950	1150	6000	1050
	75	5900	1175	5900	1175	5900	1175	5900	1075
420x65	40	6750	1350	6750	1350	6250	1250	6250	1100
	75	6150	1225	6150	1225	6150	1225	6150	1150
150x85	40	3850	750	3850	725	3550	700	3550	550
	75	3500	700	3500	700	3500	700	3500	575
180x85	40	4300	850	4300	850	3950	750	3950	650
	75	3900	775	3900	775	3900	775	3900	675
210x85	40	4700	900	4700	900	4350	850	4350	725
	75	4300	850	4300	850	4300	850	4300	750
240x85	40	5100	1000	5100	1000	4700	900	4700	825
	75	4650	925	4650	925	4650	925	4650	850
270x85	40	5450	1050	5450	1050	5050	1000	5050	900
	75	5000	1000	5000	1000	5000	1000	5000	925
300x85	40	5800	1150	5800	1150	5400	1075	5400	975
	75	5300	1050	5300	1050	5300	1050	5300	1000
330x85	40	6150	1225	6150	1225	5700	1100	5700	1050
	75	5600	1100	5600	1100	5600	1100	5600	1075
360x85	40	6500	1300	6500	1300	6000	1200	6000	1125
	75	5900	1175	5900	1175	5900	1175	5900	1175
390x85	40	6800	1350	6800	1350	6300	1250	6300	1225
	75	6200	1200	6200	1200	6200	1200	6200	1200
420x85	40	7100	1400	7100	1400	6600	1300	6600	1300
	75	6450	1250	6450	1250	6450	1250	6450	1250

NOTES:

1. D = member depth, B = member breadth, NS = not suitable.
2. The above table was based on a batten spacing of 900 mm
3. Minimum backspan = 200% of overhang
4. Maximum birds mouth depth = 30% of depth
5. End bearing length = 35 at end supports and 35 mm. Subscript values indicate the minimum additional bearing length where required to be greater than 35 mm at end support
6. Construction loads shall not be applied to overhangs until a 190x19 mm (min) timber fascia or other fascia of equivalent stiffness is rigidly and permanently attached to the end of rafter overhangs
7. Not all sizes of SmartLam GL18 in this table are stocked in each state. Please check with your supplier before ordering

HANGING BEAM SUPPORTING CEILING LOADS ONLY AS 4055 CLASSIFICATION N1, N2 AND N3

Ceiling mass - 20 kg/m²

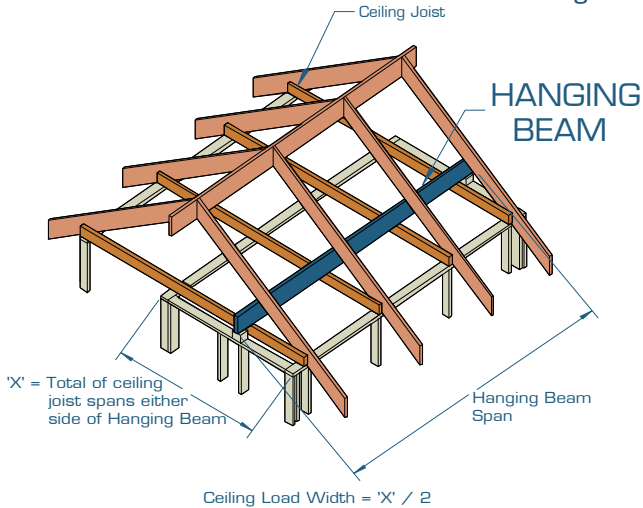

EXAMPLE:

wind speed = N3
hanging beam span = 4200 mm
X = 5000 mm

ceiling load width = $X/2 = 5000/2 = 2500$ mm

Enter column at 3000 mm ceiling load width & read down to a span greater than or equal to 4200 mm

ADOPT:

SmartLam GL18 - 180 x 65

Ceiling load width (mm)	1800	2400	3000	3600	4200	4800
Member size DxB (mm)	Maximum Hanging beam span (mm)					
150x65	4800	4400	4000	3750	3500	3300
180x65	5600	5150	4800	4500	4200	4000
210x65	6350	5850	5450	5150	4850	4650
240x65	7150	6550	6100	5750	5450	5200
270x65	7950	7300	6750	6350	6050	5750
300x65	8750	8000	7450	7000	6600	6300
330x65	9600	8750	8150	7650	7200	6850
360x65	10400	9500	8850	8300	7800	7450
390x65	11300	10300	9550	8950	8450	8000
420x65	12000	11100	10250	9600	9050	8600
450x65	12000	11900	11000	10300	9700	9200
480x65	12000	12000	11750	11000	10350	9800
510x65	12000	12000	12000	11700	11000	10450
150x85	5150	4700	4400	4100	3800	3600
180x85	5950	5500	5150	4850	4600	4350
210x85	6800	6250	5850	5500	5200	5000
240x85	7650	7050	6550	6150	5850	5600
270x85	8500	7800	7300	6850	6500	6200
300x85	9350	8600	8000	7550	7150	6800
330x85	10250	9400	8750	8200	7800	7400
360x85	11150	10250	9500	8950	8450	8050
390x85	12000	11050	10300	9650	9100	8650
420x85	12000	11950	11100	10400	9800	9300
450x85	12000	12000	11900	11150	10500	9950
480x85	12000	12000	12000	11900	11200	10650
510x85	12000	12000	12000	12000	11950	11350
540x85	12000	12000	12000	12000	12000	12000
570x85	12000	12000	12000	12000	12000	12000

NOTES:

1. D = member depth, B = member breadth, NS = not suitable.
2. The above table was based on a maximum ceiling mass of 20 (kg/m²).
3. Minimum bearing length = 70 mm at end supports.
4. Restraint value for slenderness calculations is 1500 mm
5. Value in subscript indicate extra bearing length required
6. Not all sizes of SmartLam GL18 in this table are stocked in each state. Please check with your supplier before ordering

HANGING BEAM SUPPORTING CEILING LOADS ONLY AS 4055 CLASSIFICATION C1, C2 AND C3

Ceiling mass - 20 kg/m²

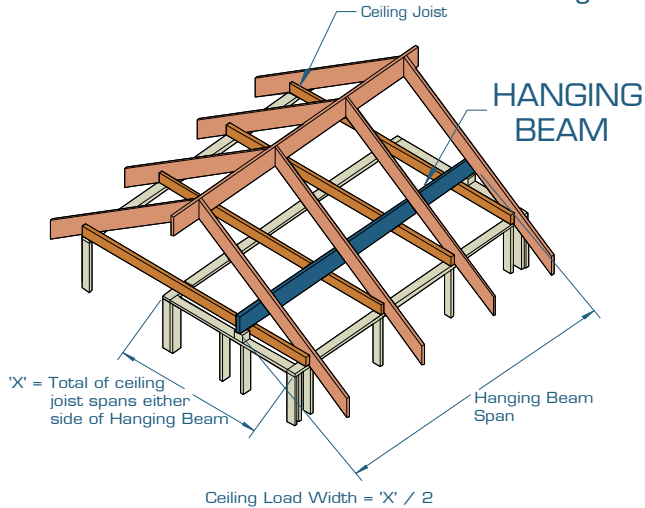

EXAMPLE:

wind speed = N3
hanging beam span = 4200 mm
X = 5000 mm

ceiling load width = $X/2 = 5000/2 = 2500$ mm

Enter column at 3000 mm ceiling load width & read down to a span greater than or equal to 4200 mm

ADOPT:

SmartLam GL18 - 210 x 65

Ceiling load width (mm)	1800	2400	3000	3600	4200	4800
Member size DxB (mm)	Maximum Hanging beam span (mm)					
150x65	4100	3600	3200	2900	2700	2500
180x65	4950	4300	3850	3500	3250	3000
210x65	5750	5000	4450	4050	3750	3500
240x65	6550	5700	5100	4650	4300	4000
270x65	7400	6400	5750	5250	4850	4500
300x65	8200	7100	6350	5800	5350	5000
330x65	8950	7750	6950	6350	5850	5450
360x65	9700	8400	7500	6850	6350	5900
390x65	10400	9050	8100	7350	6800	6350
420x65	11100	9650	8650	7900	7300	6800
450x65	11850	10250	9200	8400	7750	7250
480x65	12000	10900	9750	8900	8250	7700
510x65	12000	11500	10300	9400	8700	8150
150x85	4500	4100	3650	3350	3100	2850
180x85	5400	4900	4400	4000	3700	3450
210x85	6300	5700	5100	4650	4300	4000
240x85	7200	6500	5800	5300	4900	4600
270x85	8100	7300	6550	5950	5500	5150
300x85	9000	8100	7250	6650	6150	5750
330x85	9900	8850	7900	7250	6700	6250
360x85	10800	9550	8550	7800	7250	6750
390x85	11700	10300	9200	8400	7800	7250
420x85	12000	11000	9850	9000	8300	7800
450x85	12000	11700	10500	9550	8850	8300
480x85	12000	12000	11100	10150	9400	8800
510x85	12000	12000	11750	10700	9900	9250
540x85	12000	12000	12000	11300	10450	9750
570x85	12000	12000	12000	11850	10950	10250

NOTES:

1. D = member depth, B = member breadth, NS = not suitable.
2. The above table was based on a maximum ceiling mass of 20 (kg/m²).
3. Minimum bearing length = 70 mm at end supports.
4. Restraint value for slenderness calculations is 1500 mm
5. Value in subscript indicate extra bearing length required
6. Not all sizes of SmartLam GL18 in this table are stocked in each state. Please check with your supplier before ordering

COUNTER BEAM SUPPORTING HANGING BEAM AS 4055 CLASSIFICATION N1, N2 AND N3

Ceiling mass - 20 kg/m²

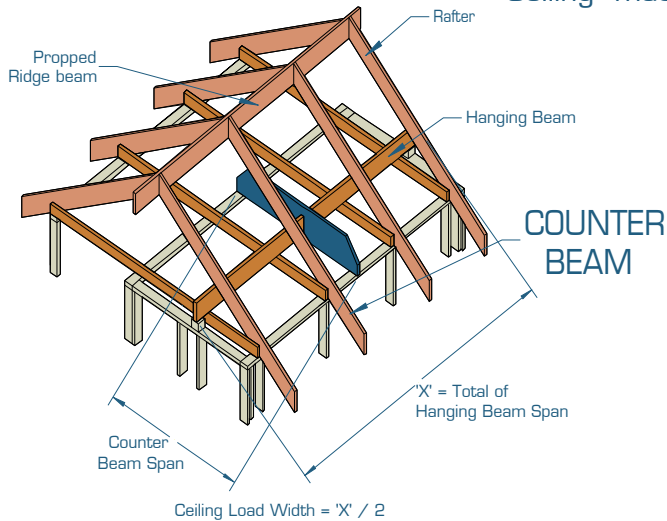

EXAMPLE:

wind speed = N3
total of hanging beam span = 6400 mm
ceiling load width = $X / 2 = 6400 / 2 = 3200$ mm

counter beam span = 4500 mm

Enter column at 3600 mm ceiling load width and read down to a span greater than or equal to 4500 mm

ADOPT:

SmartLam GL18 - 180 x 65

Note: Not all sizes of SmartLam GL18 in this table are stocked in each state. Please check with your supplier before ordering.

Ceiling load width (mm)	600	1800	2400	3000	3600	4200	4800	5400	6600
Member size DxB (mm)	Maximum Counter beam span (mm)								
150x65	6700	5300	4950	4650	4400	4100	3800	3600	3250
180x65	7750	6150	5750	5400	5200	4900	4600	4300	3900
210x65	8800	7000	6550	6200	5900	5650	5350	5050	4550
240x65	9900	7900	7350	6950	6600	6350	6100	5750	5200
270x65	10950	8750	8150	7700	7350	7050	6800	6450	5850
300x65	12000	9650	9000	8500	8100	7750	7500	7150	6500
330x65	12000	10550	9850	9300	8850	8500	8200	7800	7100
360x65	12000	11500	10700	10100	9600	9200	8900	8450	7650
390x65	12000	12000	11600	10950	10400	9950	9600	9100	8250
420x65	12000	12000	12000	11750	11200	10700	10300	9700	8800
450x65	12000	12000	12000	12000	12000	11500	10950	10350	9400
480x65	11200	12000	12000	12000	12000	12000	12000	11600	10950
510x65	10200	12000	12000	12000	12000	12000	12000	12000	11600
150x85	7000	5600	5250	5000	4750	4600	4350	4100	3750
180x85	8100	6550	6100	5800	5550	5350	5150	4950	4450
210x85	9200	7450	7000	6600	6300	6050	5850	5700	5200
240x85	10300	8400	7850	7450	7100	6800	6600	6400	5950
270x85	11400	9300	8700	8250	7900	7600	7300	7100	6700
300x85	12000	10250	9600	9100	8700	8350	8050	7800	7400
330x85	12000	11250	10500	9950	9500	9100	8800	8500	8050
360x85	12000	12000	11450	10850	10350	9900	9550	9250	8750
390x85	12000	12000	12000	11700	11200	10750	10350	10000	9400
420x85	12000	12000	12000	12000	12000	11550	11150	10800	10050
450x85	12000	12000	12000	12000	12000	12000	11950	11550	10700
480x85	10500	12000	12000	12000	12000	12000	12000	12000	11350
510x85	9950	12000	12000	12000	12000	12000	12000	12000	11950
540x85	9650	12000	12000	12000	12000	12000	12000	12000	12000
570x85	9450	10450	12000	12000	12000	12000	12000	12000	12000

NOTES:

1. D = member depth, B = member breadth, NS = not suitable.
2. The above table was based on a maximum ceiling mass of 20 (kg/m²).
3. Minimum bearing length = 70 mm at end supports.
4. Restraint value for slenderness calculations is 1500 mm
5. Value in subscript indicate extra bearing length required
6. Not all sizes of SmartLam GL18 in this table are stocked in each state. Please check with your supplier before ordering

COUNTER BEAM SUPPORTING HANGING BEAM AS 4055 CLASSIFICATION C1, C2 AND C3

Ceiling mass - 20 kg/m²

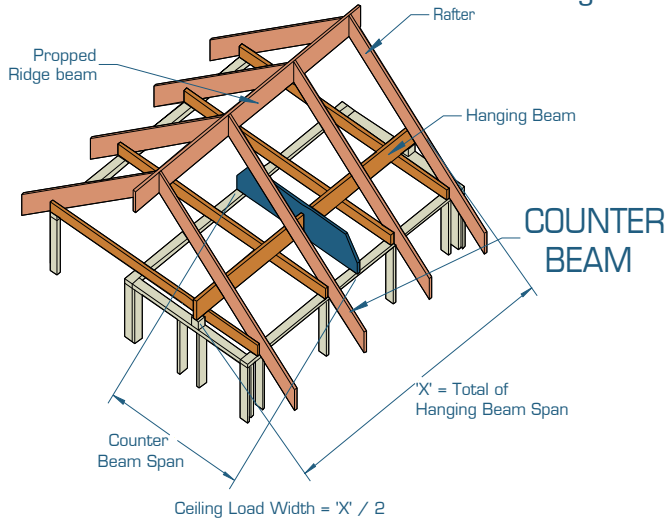

EXAMPLE:

wind speed = N3
total of hanging beam span = 6400 mm
ceiling load width = $X / 2 = 6400 / 2 = 3200$ mm

counter beam span = 4500 mm

Enter column at 3600 mm ceiling load width and read down to a span greater than or equal to 4500 mm

ADOPT:

SmartLam GL18 - 240 x 65

Note: Not all sizes of SmartLam GL18 in this table are stocked in each state. Please check with your supplier before ordering.

Ceiling load width (mm)	600	1800	2400	3000	3600	4200	4800	5400	6600
Member size DxB (mm)	Maximum Counter beam span (mm)								
150x65	6700	4150	3600	3200	2950	2700	2550	2400	2150
180x65	7750	5000	4300	3850	3500	3250	3050	2850	2600
210x65	8800	5800	5050	4500	4100	3800	3550	3350	3050
240x65	9900	6650	5750	5150	4700	4350	4050	3850	3450
270x65	10950	7450	6500	5800	5300	4900	4600	4300	3900
300x65	12000	8250	7200	6450	5900	5450	5100	4800	4350
330x65	12000	9000	7850	7000	6400	5950	5550	5250	4750
360x65	12000	9750	8500	7600	6950	6450	6000	5650	5150
390x65	12000	10500	9100	8150	7500	6950	6500	6100	5500
420x65	12000	11200	9750	8750	8000	7400	6950	6550	5900
450x65	12000	11900	10350	9300	8500	7900	7400	6950	6300
480x65	11200	12000	11000	9850	9000	8350	7850	7400	6700
510x65	10200	12000	11600	10400	9550	8850	8300	7800	7050
150x85	7000	4750	4100	3700	3350	3100	2900	2750	2500
180x85	8100	5700	4950	4400	4050	3750	3500	3300	2950
210x85	9200	6650	5750	5150	4700	4350	4050	3850	3450
240x85	10300	7550	6550	5900	5400	5000	4650	4400	3950
270x85	11400	8500	7400	6600	6050	5600	5250	4950	4450
300x85	12000	9400	8200	7350	6700	6250	5850	5500	4950
330x85	12000	10250	8950	8000	7350	6800	6350	6000	5400
360x85	12000	11100	9650	8650	7950	7350	6900	6500	5850
390x85	12000	11900	10400	9300	8500	7900	7400	7000	6300
420x85	12000	12000	11100	9950	9100	8450	7900	7450	6750
450x85	12000	12000	11800	10600	9700	9000	8450	7950	7200
480x85	10500	12000	12000	11250	10300	9550	8950	8450	7650
510x85	9950	12000	12000	11850	10850	10100	9450	8900	8100
540x85	9650	12000	12000	12000	11450	10600	9950	9400	8500
570x85	9450	10450	12000	12000	12000	11150	10450	9850	8950

NOTES:

1. D = member depth, B = member breadth, NS = not suitable
2. The above table was based on a maximum ceiling mass of 20 (kg/m²).
3. Minimum bearing length = 70 mm at end supports
4. Not all sizes of SmartLam GL18 in this table are stocked in each state. Please check with your supplier before ordering

STRUTTING BEAM SUPPORTING UNDERPURLINS AS 4055 CLASSIFICATION N1, N2 AND N3

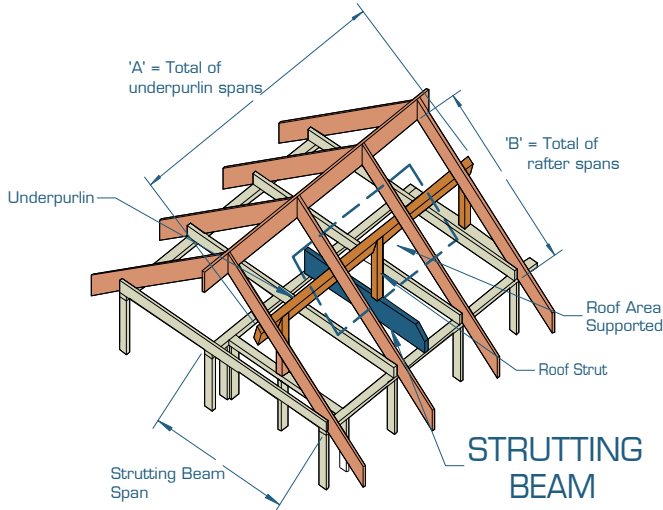

EXAMPLE:

wind speed = N3
 sheet roof = 40kg/m²
 total of underpurlin span 'A' = 5000 mm
 total of rafter span 'B' = 4200 mm
 roof area supported = (A/2) x (B/2)
 = (5000/2) x (4200/2)
 = 5250000 mm² (Convert to m²)
 = 5250000/1000000 = 5.25 m²

strutting beam span = 4500 mm

Enter column at 6 m² roof area supported and read down to a span greater than or equal to 4500 mm

ADOPT:

SmartLam GL18 - 210 x 65

Roof area supported (m ²)		2	4	6	8	10	12
Member size DxB (mm)	Roof mass (kg/m ²)	Maximum Strutting beam span (mm)					
150x65	20	4900	4750	3700	2750	2200	1800
	60	4650	3350	2750	2350	2000	1650
180x65	20	5900	5700	5250	3950	3150	2650
	60	5700	4500	3650	3150	2800	2400
210x65	20	6900	6650	6250	5450	4300	3600
	60	6800	5350	4650	4050	3600	3250
240x65	20	7900	7600	7300	6600	5650	4700
	60	7900	6250	5400	4850	4450	4050
270x65	20	8850	8550	8250	7600	7050	6000
	60	8850	7200	6200	5550	5100	4800
300x65	20	9850	9500	9200	8650	8000	7400
	60	9850	8200	7050	6300	5800	5400
330x65	20	10850	10450	10100	9800	9050	8450
	60	10850	9250	7950	7100	6500	6050
360x65	20	11800	11400	11000	10700	10150	9450
	60	11800	10400	8950	7950	7300	6750
390x65	20	12000	12000	11950	11600	11250	10550
	60	12000	11550	9950	8850	8100	7500
420x65	20	10850	11850	12000	12000	12000	11700
	60	12000	12000	11000	9800	8950	8300
450x65	20	10150	10450	10900	11500	12000	12000
	60	10600	12000	12000	10850	9850	9100
480x65	20	9750	10000	10250	10500	10850	11250
	60	10050	10750	11850	11900	10850	10000
510x65	20	9550	9700	9900	10050	10300	10500
	60	9750	10200	10800	11650	11850	10950
150x85	20	5400	5200	4700	3600	2900	2400
	60	5100	3850	3150	2700	2400	2200
180x85	20	6450	6250	5750	5200	4150	3450
	60	6200	4950	4200	3600	3200	2950
210x85	20	7550	7250	6800	6200	5700	4700
	60	7350	5900	5100	4600	4150	3750
240x85	20	8600	8300	7950	7250	6700	6200
	60	8550	6850	5950	5350	4950	4600
270x85	20	9700	9350	9050	8350	7750	7250
	60	9700	7900	6850	6150	5650	5300
300x85	20	10750	10400	10050	9500	8800	8250
	60	10750	9000	7800	7000	6450	6000
330x85	20	11850	11400	11050	10700	9950	9350
	60	11850	10150	8800	7900	7250	6750
360x85	20	12000	12000	12000	11700	11100	10450
	60	12000	11350	9900	8850	8100	7550
390x85	20	12000	12000	12000	12000	12000	11600
	60	12000	12000	11000	9850	9050	8400
420x85	20	10700	11250	12000	12000	12000	12000
	60	11550	12000	12000	10950	10000	9300
450x85	20	10050	10300	10600	10900	11350	12000
	60	10400	11200	12000	12000	11050	10250
480x85	20	9700	9900	10050	10250	10450	10700
	60	9950	10400	11000	11950	12000	11250
510x85	20	9500	9600	9750	9900	10050	10200
	60	9650	10000	10350	10850	11450	12000
540x85	20	9350	9450	9550	9650	9750	9900
	60	9450	9700	10000	10350	10700	11150
570x85	20	9200	9300	9400	9500	9600	9650
	60	9350	9550	9750	10000	10300	10600

STRUTTING BEAM SUPPORTING UNDERPURLINS AS 4055 CLASSIFICATION C1, C2 AND C3

Roof area supported (m ²)		2	4	6	8	10	12
Member size DxB (mm)	Roof mass (kg/m ²)	Maximum Strutting beam span (mm)					
150x65	20	4900	3600	2400	1800	1400	1200
	60	4650	3350	2550	1900	1500	1250
180x65	20	5900	5200	3450	2600	2050	1700
	60	5700	4500	3650	2750	2200	1850
210x65	20	6900	6650	4700	3500	2800	2350
	60	6800	5350	4650	3750	3000	2500
240x65	20	7900	7600	6200	4600	3700	3050
	60	7900	6250	5400	4850	3900	3250
270x65	20	8850	8550	7900	5850	4650	3900
	60	8850	7200	6200	5550	4900	4100
300x65	20	9850	9500	9200	7250	5800	4800
	60	9850	8200	7050	6300	5800	5050
330x65	20	10850	10450	10100	8700	6900	5750
	60	10850	9250	7950	7100	6500	6000
360x65	20	11800	11400	11000	10250	8150	6750
	60	11800	10400	8950	7950	7300	6750
390x65	20	12000	12000	11950	11600	9450	7850
	60	12000	11550	9950	8850	8100	7500
420x65	20	10850	11850	12000	12000	10900	9000
	60	12000	12000	11000	9800	8950	8300
450x65	20	10150	10450	10900	11500	12000	10250
	60	10600	12000	12000	10850	9850	9100
480x65	20	9750	10000	10250	10500	10850	11250
	60	10050	10750	11850	11900	10850	10000
510x65	20	9550	9700	9900	10050	10300	10500
	60	9750	10200	10800	11650	11850	10950
150x85	20	5400	4750	3150	2350	1850	1550
	60	5100	3850	3150	2500	2000	1650
180x85	20	6450	6250	4550	3400	2700	2250
	60	6200	4950	4200	3600	2900	2400
210x85	20	7550	7250	6200	4650	3700	3050
	60	7350	5900	5100	4600	3900	3250
240x85	20	8600	8300	7950	6050	4850	4000
	60	8550	6850	5950	5350	4950	4250
270x85	20	9700	9350	9050	7750	6150	5100
	60	9700	7900	6850	6150	5650	5300
300x85	20	10750	10400	10050	9500	7600	6300
	60	10750	9000	7800	7000	6450	6000
330x85	20	11850	11400	11050	10700	9100	7550
	60	11850	10150	8800	7900	7250	6750
360x85	20	12000	12000	12000	11700	10750	8900
	60	12000	11350	9900	8850	8100	7550
390x85	20	12000	12000	12000	12000	12000	10350
	60	12000	12000	11000	9850	9050	8400
420x85	20	10700	11250	12000	12000	12000	11950
	60	11550	12000	12000	10950	10000	9300
450x85	20	10050	10300	10600	10900	11350	12000
	60	10400	11200	12000	12000	11050	10250
480x85	20	9700	9900	10050	10250	10450	10700
	60	9950	10400	11000	11950	12000	11250
510x85	20	9500	9600	9750	9900	10050	10200
	60	9650	10000	10350	10850	11450	12000
540x85	20	9350	9450	9550	9650	9750	9900
	60	9450	9700	10000	10350	10700	11150
570x85	20	9200	9300	9400	9450	9550	9650
	60	9350	9550	9750	10000	10300	10600

NOTES:

1. D = member depth, B = member breadth, NS = not suitable.
2. Minimum bearing length = 70 mm at end supports
3. Restraint value for slenderness calculations is 1500 mm
4. Not all sizes of SmartLam GL18 in this table are stocked in each state. Please check with your supplier before ordering

STRUTTING/COUNTER BEAM SUPPORTING UNDERPURLINS & HANGING BEAM - AS 4055 CLASSIFICATION N1, N2 AND N3

Ceiling mass - 20 kg/m²

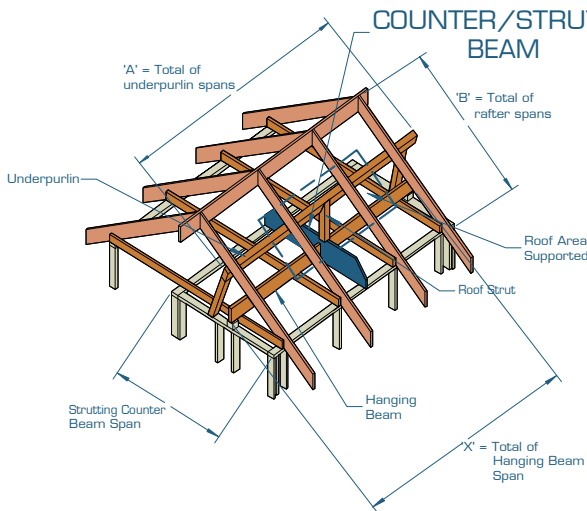

EXAMPLE:

wind speed = N3
 sheet roof = 40 kg/m²
 total of underpurlin span 'A' = 5000 mm
 total of rafter span 'B' = 4200 mm
 roof area supported = (A/2) x (B/2)
 = (5000/2) x (4200/2)
 = 5250000 mm² (Convert to m²)
 = 5250000/1000000 = 5.25 m²

total of hanging beam span 'X' = 4500 mm
 effective beam spacing = 'X' / 2 = 4500 / 2 = 2250 mm
 strutting/counter beam span = 4500 mm

Enter column at 3600 mm effective beam spacing, 6 m² roof area supported and read down to a span greater than or equal to 4500 mm

ADOPT:

SmartLam GL18 - 240x65 65

Note: Not all sizes of SmartLam GL18 in this table are stocked in each state. Please check with your supplier before ordering.

Effective beam spacing (mm)		1800						3600					
Roof area supported (m ²)		2	4	6	8	10	12	2	4	6	8	10	12
Member size DxB (mm)	Roof mass (kg/m ²)	Maximum Strutting beam span (mm)											
150x65	40	3950	3400	2950	2650	2350	1950	3550	3100	2750	2500	2250	1900
	75	3600	2800	2350	2050	1850	1650	3250	2650	2250	2000	1800	1600
180x65	40	4700	4150	3750	3450	3150	2800	4200	3850	3550	3200	3000	2700
	75	4300	3650	3100	2750	2450	2250	3950	3400	2950	2650	2400	2200
210x65	40	5450	4850	4400	4100	3850	3650	4800	4450	4100	3900	3700	3450
	75	5000	4300	3800	3450	3100	2850	4550	4000	3650	3300	3000	2800
240x65	40	6200	5550	5100	4700	4450	4200	5400	5050	4700	4450	4200	4000
	75	5700	4950	4400	4050	3750	3500	5150	4600	4200	3900	3650	3400
270x65	40	6900	6250	5750	5350	5050	4800	6050	5650	5300	5000	4750	4550
	75	6450	5600	5000	4600	4300	4050	5750	5150	4750	4400	4150	3900
300x65	40	7700	7000	6450	6050	5650	5400	6650	6250	5900	5600	5300	5100
	75	7200	6300	5650	5200	4800	4550	6350	5750	5300	4950	4650	4400
330x65	40	8450	7750	7200	6700	6350	6000	7300	6850	6500	6150	5900	5650
	75	7950	7000	6300	5800	5400	5050	7000	6350	5850	5450	5150	4900
360x65	40	9200	8500	7900	7400	7000	6650	7900	7500	7100	6750	6500	6200
	75	8700	7700	6950	6400	5950	5600	7600	6950	6450	6050	5700	5400
390x65	40	10000	9300	8650	8150	7700	7300	8550	8100	7750	7400	7050	6800
	75	9500	8450	7650	7050	6550	6200	8250	7600	7050	6600	6200	5900
420x65	40	10800	10050	9450	8900	8450	8000	9200	8750	8350	8000	7700	7400
	75	10250	9200	8400	7750	7200	6750	8900	8200	7650	7200	6800	6450
450x65	40	11600	10850	10200	9650	9150	8750	9850	9400	9000	8650	8300	8000
	75	11050	10000	9150	8450	7850	7400	9550	8850	8300	7800	7350	7000
480x65	40	12000	11650	11050	10450	9950	9500	10500	10050	9650	9300	8950	8650
	75	11900	10800	9900	9150	8550	8050	10200	9500	8900	8400	7950	7550
510x65	40	12000	12000	11850	11250	10700	10250	11150	10750	10300	9950	9600	9250
	75	12000	11600	10700	9900	9250	8700	10850	10150	9550	9050	8550	8150
150x85	40	4300	3800	3350	3000	2700	2500	3850	3450	3100	2850	2600	2400
	75	3900	3200	2700	2350	2100	1950	3600	3000	2600	2300	2050	1900
180x85	40	5100	4500	4100	3800	3550	3300	4500	4150	3850	3650	3350	3150
	75	4650	4000	3550	3100	2800	2600	4250	3750	3350	3000	2750	2500
210x85	40	5850	5300	4850	4500	4200	4000	5200	4800	4500	4250	4000	3850
	75	5450	4700	4200	3850	3550	3250	4900	4400	4000	3700	3450	3200
240x85	40	6650	6050	5550	5200	4850	4600	5850	5450	5100	4850	4600	4400
	75	6200	5400	4850	4450	4150	3900	5550	5000	4600	4250	4000	3800
270x85	40	7450	6800	6300	5900	5550	5250	6500	6100	5750	5450	5200	5000
	75	7000	6150	5500	5050	4700	4450	6200	5650	5200	4850	4550	4300
300x85	40	8300	7600	7050	6600	6250	5950	7200	6750	6400	6100	5850	5600
	75	7800	6900	6200	5700	5300	5000	6900	6300	5800	5400	5100	4850
330x85	40	9100	8400	7850	7400	6950	6650	7850	7450	7050	6750	6450	6200
	75	8600	7650	6950	6400	5950	5600	7550	6950	6450	6000	5700	5400
360x85	40	9950	9250	8650	8150	7700	7350	8550	8100	7750	7400	7100	6850
	75	9450	8450	7700	7100	6600	6200	8250	7600	7100	6650	6250	5950
390x85	40	10750	10100	9500	8950	8500	8100	9250	8800	8450	8100	7750	7500
	75	10300	9250	8450	7800	7300	6850	8950	8300	7750	7250	6850	6550
420x85	40	11600	10950	10300	9800	9300	8900	9950	9500	9100	8750	8450	8150
	75	11150	10100	9250	8550	8000	7550	9650	9000	8400	7900	7500	7150
450x85	40	12000	11800	11200	10600	10100	9700	10650	10200	9800	9450	9150	8800
	75	12000	10950	10100	9350	8750	8250	10350	9700	9100	8600	8150	7750
480x85	40	12000	12000	12000	11500	10950	10500	11350	10950	10550	10150	9850	9500
	75	12000	11800	10900	10150	9500	9000	11050	10400	9800	9250	8800	8400
510x85	40	12000	12000	12000	12000	11850	11350	12000	11650	11250	10900	10550	10200
	75	12000	12000	11800	11000	10300	9750	11800	11100	10500	9950	9500	9050
540x85	40	12000	12000	12000	12000	12000	12000	12000	12000	12000	11600	11250	10950
	75	12000	12000	12000	11850	11150	10550	12000	11850	11250	10700	10200	9750
570x85	40	12000	12000	12000	12000	12000	12000	12000	12000	12000	12000	12000	11650
	75	12000	12000	12000	12000	12000	11350	12000	12000	11950	11400	10900	10450

STRUTTING/COUNTER BEAM SUPPORTING UNDERPURLINS & HANGING BEAM - AS 4055 CLASSIFICATION C1, C2 AND C3

Ceiling mass - 20 kg/m²

Note: Not all sizes of SmartLam GL18 in this table are stocked in each state. Please check with your supplier before ordering.

Effective beam spacing (mm)		1800						3600					
Roof Area Supported (m ²)		2	4	6	8	10	12	2	4	6	8	10	12
Member size DxB (mm)	Roof mass (kg/m ²)	Maximum Strutting beam span (mm)											
150x65	40	3950	2550	1650	1250	1000	NS	3550	2650	1700	1250	1000	NS
	75	3600	2750	1800	1350	1050	NS	3250	2650	1800	1350	1050	NS
180x65	40	4700	3750	2450	1800	1450	1200	4200	3850	2450	1800	1450	1200
	75	4300	3650	2600	1950	1550	1250	3950	3400	2650	1950	1550	1300
210x65	40	5450	4850	3350	2450	1950	1650	4800	4450	3400	2500	2000	1650
	75	5000	4300	3600	2650	2100	1750	4550	4000	3650	2700	2100	1750
240x65	40	6200	5550	4400	3250	2600	2150	5400	5050	4550	3300	2600	2150
	75	5700	4950	4400	3500	2750	2300	5150	4600	4200	3550	2800	2300
270x65	40	6900	6250	5650	4150	3300	2700	6050	5650	5300	4250	3300	2750
	75	6450	5600	5000	4450	3500	2900	5750	5150	4750	4400	3550	2950
300x65	40	7700	7000	6450	5150	4050	3350	6650	6250	5900	5300	4150	3400
	75	7200	6300	5650	5200	4350	3600	6350	5750	5300	4950	4450	3650
330x65	40	8450	7750	7200	6200	4850	4000	7300	6850	6500	6150	5000	4100
	75	7950	7000	6300	5800	5250	4300	7000	6350	5850	5450	5150	4400
360x65	40	9200	8500	7900	7350	5750	4750	7900	7500	7100	6750	5900	4800
	75	8700	7700	6950	6400	5950	5100	7600	6950	6450	6050	5700	5200
390x65	40	10000	9300	8650	8150	6700	5500	8550	8100	7750	7400	6950	5650
	75	9500	8450	7650	7050	6550	5900	8250	7600	7050	6600	6200	5900
420x65	40	10800	10050	9450	8900	7750	6350	9200	8750	8350	8000	7700	6500
	75	10250	9200	8400	7750	7200	6750	8900	8200	7650	7200	6800	6450
450x65	40	11600	10850	10200	9650	8900	7250	9850	9400	9000	8650	8300	7500
	75	11050	10000	9150	8450	7850	7400	9550	8850	8300	7800	7350	7000
480x65	40	12000	11650	11050	10450	9950	8250	10500	10050	9650	9300	8950	8550
	75	11900	10800	9900	9150	8550	8050	10200	9500	8900	8400	7950	7550
510x65	40	12000	12000	11850	11250	10700	9250	11150	10750	10300	9950	9600	9250
	75	12000	11600	10700	9900	9250	8700	10850	10150	9550	9050	8550	8150
150x85	40	4300	3400	2200	1650	1300	1050	3850	3450	2250	1650	1300	1100
	75	3900	3200	2350	1750	1400	1150	3600	3000	2400	1750	1400	1150
180x85	40	5100	4500	3200	2350	1900	1550	4500	4150	3300	2400	1900	1550
	75	4650	4000	3450	2550	2000	1650	4250	3750	3350	2600	2050	1700
210x85	40	5850	5300	4400	3250	2600	2150	5200	4800	4500	3300	2600	2150
	75	5450	4700	4200	3500	2750	2300	4900	4400	4000	3550	2800	2300
240x85	40	6650	6050	5550	4300	3400	2800	5850	5450	5100	4400	3450	2850
	75	6200	5400	4850	4450	3650	3000	5550	5000	4600	4250	3700	3050
270x85	40	7450	6800	6300	5500	4300	3550	6500	6100	5750	5450	4400	3600
	75	7000	6150	5500	5050	4650	3800	6200	5650	5200	4850	4550	3900
300x85	40	8300	7600	7050	6600	5350	4450	7200	6750	6400	6100	5500	4500
	75	7800	6900	6200	5700	5300	4750	6900	6300	5800	5400	5100	4850
330x85	40	9100	8400	7850	7400	6450	5300	7850	7450	7050	6750	6450	5400
	75	8600	7650	6950	6400	5950	5600	7550	6950	6450	6000	5700	5400
360x85	40	9950	9250	8650	8150	7650	6250	8550	8100	7750	7400	7100	6450
	75	9450	8450	7700	7100	6600	6200	8250	7600	7100	6650	6250	5950
390x85	40	10750	10100	9500	8950	8500	7300	9250	8800	8450	8100	7750	7500
	75	10300	9250	8450	7800	7300	6850	8950	8300	7750	7250	6850	6550
420x85	40	11600	10950	10300	9800	9300	8450	9950	9500	9100	8750	8450	8150
	75	11150	10100	9250	8550	8000	7550	9650	9000	8400	7900	7500	7150
450x85	40	12000	11800	11200	10600	10100	9700	10650	10200	9800	9450	9150	8800
	75	12000	10950	10100	9350	8750	8250	10350	9700	9100	8600	8150	7750
480x85	40	12000	12000	12000	11500	10950	10500	11350	10950	10550	10150	9850	9500
	75	12000	11800	10900	10150	9500	9000	11050	10400	9800	9250	8800	8400
510x85	40	12000	12000	12000	12000	11850	11350	12000	11650	11250	10900	10550	10200
	75	12000	12000	11800	11000	10300	9750	11800	11100	10500	9950	9500	9050
540x85	40	12000	12000	12000	12000	12000	12000	12000	12000	12000	11600	11250	10950
	75	12000	12000	12000	11850	11150	10550	12000	11850	11250	10700	10200	9750
570x85	40	12000	12000	12000	12000	12000	12000	12000	12000	12000	12000	12000	11650
	75	12000	12000	12000	12000	12000	11350	12000	12000	11950	11400	10900	10450

NOTES:

1. D = member depth, B = member breadth, NS = not suitable.
2. Minimum bearing length = 70 mm at end supports.
3. The above table was based on a maximum ceiling mass of 20 (kg/m²).
4. Restraint value for slenderness calculations is 1500 mm
5. Not all sizes of SmartLam GL18 in this table are stocked in each state. Please check with your supplier before ordering

STRUTTING/HANGING BEAM AS 4055 CLASSIFICATION N1, N2 AND N3

Ceiling mass - 20 kg/m²

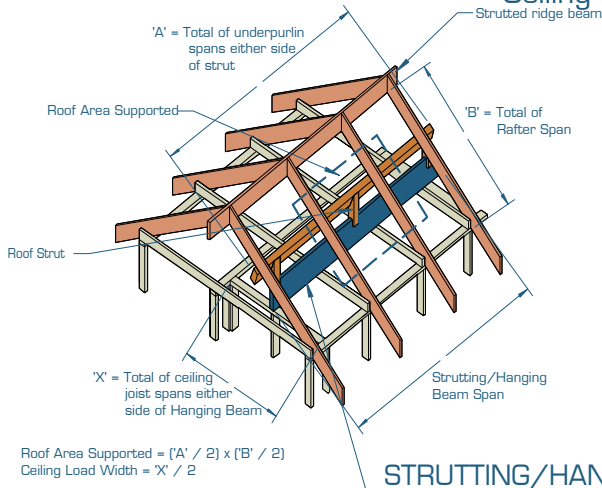

EXAMPLE:

wind speed = N3
 sheet roof = 40kg/m²
 $A = \text{roof area supported} = (A/2) \times (B/2)$
 $= (5000/2) \times (4200/2)$
 $= 5250000 \text{ mm}^2$ **(Convert to m²)**
 $= 5250000 / 1000000 = 5.25 \text{ m}^2$
 strutting/hanging beam span = 4200 mm
 ceiling joist span ('X') = 4400 mm
 ceiling load width = ['X' / 2] = 4400/2 = 2200 mm

Enter column at 3600 mm ceiling load width, 6 m² roof area supported and read down to a span greater than or equal to 4200 mm

ADOPT:

SmartLam GL18 - 240 x 65

STRUTTING/HANGING BEAM

Ceiling load width (mm)		1800						3600					
Roof area supported (m ²)		2	4	6	8	10	12	2	4	6	8	10	12
Member size DxB (mm)	Roof mass (kg/m ²)	Maximum Strutting/Hanging beam span (mm)											
150x65	40	3850	3300	2900	2600	2300	1950	3250	2900	2600	2400	2200	1900
	75	3500	2750	2350	2050	1850	1650	3000	2500	2200	1950	1750	1600
180x65	40	4600	4050	3700	3400	3100	2800	3900	3650	3350	3050	2850	2700
	75	4200	3600	3050	2700	2450	2250	3700	3200	2850	2550	2350	2150
210x65	40	5300	4750	4350	4050	3800	3600	4500	4200	3950	3750	3550	3350
	75	4900	4200	3800	3400	3100	2850	4300	3850	3500	3200	2950	2700
240x65	40	6050	5450	5000	4650	4400	4150	5100	4750	4500	4250	4050	3900
	75	5600	4850	4350	4000	3750	3500	4850	4400	4050	3800	3550	3300
270x65	40	6800	6150	5700	5300	5000	4750	5700	5350	5050	4800	4600	4400
	75	6350	5500	4950	4550	4250	4000	5450	4950	4600	4300	4050	3850
300x65	40	7600	6900	6400	5950	5600	5300	6300	5950	5600	5350	5150	4950
	75	7100	6200	5600	5150	4800	4500	6050	5500	5100	4800	4500	4300
330x65	40	8400	7650	7100	6650	6250	5950	6900	6550	6200	5950	5700	5450
	75	7850	6900	6250	5750	5350	5050	6650	6100	5650	5300	5000	4800
360x65	40	9200	8450	7850	7350	6950	6600	7550	7150	6800	6500	6250	6000
	75	8650	7650	6900	6350	5900	5550	7250	6700	6200	5850	5550	5250
390x65	40	10050	9250	8650	8100	7650	7250	8200	7800	7400	7100	6850	6600
	75	9500	8400	7600	7000	6500	6150	7900	7300	6800	6400	6050	5750
420x65	40	10900	10100	9450	8900	8400	8000	8850	8400	8050	7700	7450	7150
	75	10350	9200	8350	7700	7150	6750	8550	7900	7400	6950	6600	6300
450x65	40	11800	10950	10300	9700	9150	8700	9500	9100	8700	8350	8050	7750
	75	11200	10000	9100	8400	7850	7350	9200	8550	8000	7550	7150	6850
480x65	40	12000	11850	11150	10500	9950	9500	10200	9750	9350	9000	8700	8400
	75	12000	10900	9900	9150	8500	8000	9900	9200	8650	8150	7750	7400
510x65	40	12000	12000	12000	11350	10800	10300	10900	10450	10050	9700	9350	9050
	75	12000	11750	10750	9900	9250	8700	10600	9900	9300	8800	8350	7950
150x85	40	4150	3700	3300	2950	2700	2500	3600	3250	2950	2700	2500	2350
	75	3800	3150	2650	2350	2100	1950	3350	2850	2500	2250	2050	1850
180x85	40	4950	4450	4050	3750	3500	3250	4250	3950	3700	3450	3250	3050
	75	4550	3950	3500	3100	2800	2550	4000	3600	3200	2900	2650	2450
210x85	40	5750	5200	4750	4450	4150	3950	4850	4550	4300	4050	3900	3700
	75	5350	4600	4150	3800	3550	3250	4650	4200	3850	3600	3350	3100
240x85	40	6550	5950	5500	5100	4800	4550	5500	5150	4900	4650	4450	4250
	75	6100	5300	4800	4400	4100	3850	5250	4800	4450	4150	3900	3700
270x85	40	7350	6750	6200	5800	5500	5200	6150	5800	5500	5250	5050	4850
	75	6900	6050	5450	5000	4700	4400	5900	5400	5000	4700	4450	4200
300x85	40	8200	7550	7000	6550	6200	5900	6800	6450	6150	5850	5600	5400
	75	7750	6800	6150	5650	5300	5000	6550	6000	5600	5250	4950	4750
330x85	40	9100	8400	7800	7300	6900	6550	7500	7100	6800	6500	6250	6000
	75	8550	7600	6900	6350	5900	5550	7200	6650	6200	5850	5500	5250
360x85	40	9950	9250	8650	8100	7700	7300	8200	7800	7450	7150	6850	6600
	75	9450	8400	7650	7050	6550	6200	7900	7300	6850	6450	6100	5800
390x85	40	10900	10150	9500	8950	8450	8050	8900	8500	8100	7800	7500	7250
	75	10350	9250	8450	7800	7250	6850	8600	8000	7500	7050	6700	6400
420x85	40	11800	11050	10400	9800	9300	8850	9600	9200	8850	8500	8200	7900
	75	11250	10150	9250	8550	8000	7500	9300	8700	8150	7700	7300	6950
450x85	40	12000	12000	11300	10700	10150	9700	10350	9950	9550	9200	8850	8600
	75	12000	11050	10100	9350	8750	8200	10050	9400	8850	8350	7950	7600
480x85	40	12000	12000	12000	11600	11050	10550	11100	10700	10300	9900	9600	9300
	75	12000	11950	11000	10200	9550	8950	10800	10150	9550	9050	8600	8200
510x85	40	12000	12000	12000	12000	11950	11450	11900	11450	11050	10650	10300	10000
	75	12000	12000	11900	11050	10350	9750	11600	10900	10300	9750	9300	8900
540x85	40	12000	12000	12000	12000	12000	12000	12000	12000	11800	11450	11100	10750
	75	12000	12000	12000	12000	11200	10600	12000	11650	11050	10500	10000	9550

STRUTTING/HANGING BEAM AS 4055 CLASSIFICATION C1, C2 AND C3

Ceiling mass - 20 kg/m²

Ceiling load width (mm)		1800						3600					
Roof area supported (m ²)		2	4	6	8	10	12	2	4	6	8	10	12
Member size DxB (mm)	Roof mass (kg/m ²)	Maximum Strutting/Hanging beam span (mm)											
150x65	40	3350	3050	2350	1800	1450	1200	2350	2400	2300	1750	1450	1200
	75	3450	2750	2100	1600	1300	NS	2400	2500	2050	1550	1250	NS
180x65	40	4000	4000	3250	2600	2100	1750	2800	2850	2900	2500	2050	1700
	75	4100	3600	3000	2300	1850	1550	2850	2950	2850	2250	1800	1550
210x65	40	4650	4750	4100	3450	2800	2350	3300	3350	3400	3350	2750	2300
	75	4750	4200	3800	3100	2500	2100	3300	3400	3500	3000	2450	2050
240x65	40	5300	5400	5000	4350	3650	3050	3750	3800	3850	3900	3550	3000
	75	5400	4850	4350	4000	3250	2750	3800	3850	3950	3800	3200	2700
270x65	40	6000	6100	5700	5150	4550	3850	4200	4250	4300	4350	4400	3750
	75	6050	5500	4950	4550	4100	3450	4250	4350	4400	4300	3950	3350
300x65	40	6650	6750	6400	5950	5400	4750	4650	4700	4750	4800	4900	4550
	75	6700	6200	5600	5150	4800	4250	4700	4800	4900	4800	4500	4100
330x65	40	7250	7350	7100	6650	6250	5600	5100	5150	5200	5250	5300	5350
	75	7300	6900	6250	5750	5350	5000	5150	5200	5300	5300	5000	4800
360x65	40	7850	7950	7850	7350	6950	6500	5500	5550	5600	5650	5700	5750
	75	7900	7650	6900	6350	5900	5550	5550	5650	5700	5800	5550	5250
390x65	40	8450	8550	8650	8100	7650	7250	5950	6000	6050	6100	6150	6200
	75	8500	8400	7600	7000	6500	6150	5950	6050	6150	6250	6050	5750
420x65	40	9000	9100	9200	8900	8400	8000	6350	6400	6450	6500	6550	6600
	75	9100	9200	8350	7700	7150	6750	6400	6450	6550	6650	6600	6300
450x65	40	9600	9700	9800	9700	9150	8700	6750	6800	6850	6900	6950	7000
	75	9700	9850	9100	8400	7850	7350	6800	6900	6950	7050	7150	6850
480x65	40	10200	10300	10400	10500	9950	9500	7200	7250	7300	7350	7400	7450
	75	10250	10450	9900	9150	8500	8000	7200	7300	7400	7450	7550	7400
510x65	40	10800	10900	11000	11100	10800	10300	7600	7650	7700	7750	7800	7850
	75	10850	11000	10750	9900	9250	8700	7600	7700	7800	7900	7950	7950
150x85	40	3850	3450	2800	2350	1900	1600	2700	2750	2800	2300	1850	1550
	75	3800	3150	2650	2100	1700	1400	2700	2800	2500	2050	1650	1400
180x85	40	4600	4450	3700	3200	2700	2250	3200	3250	3300	3200	2650	2250
	75	4550	3950	3500	3000	2400	2000	3250	3350	3200	2900	2350	2000
210x85	40	5350	5200	4700	4050	3600	3050	3750	3800	3850	3900	3550	3000
	75	5350	4600	4150	3800	3250	2750	3800	3850	3850	3600	3200	2700
240x85	40	6100	5950	5500	4950	4450	4000	4300	4350	4400	4450	4450	3850
	75	6100	5300	4800	4400	4100	3550	4300	4400	4450	4150	3900	3450
270x85	40	6850	6750	6200	5800	5300	4800	4800	4850	4900	4950	5000	4800
	75	6900	6050	5450	5000	4700	4400	4850	4950	5000	4700	4450	4200
300x85	40	7600	7550	7000	6550	6200	5650	5350	5400	5450	5500	5550	5400
	75	7650	6800	6150	5650	5300	5000	5400	5450	5550	5250	4950	4750
330x85	40	8300	8400	7800	7300	6900	6500	5850	5900	5950	6000	6050	6000
	75	8350	7600	6900	6350	5900	5550	5850	5950	6050	5850	5500	5250
360x85	40	8950	9050	8650	8100	7700	7300	6300	6350	6400	6450	6500	6550
	75	9050	8400	7650	7050	6550	6200	6350	6450	6500	6450	6100	5800
390x85	40	9650	9750	9500	8950	8450	8050	6800	6850	6900	6950	7000	7050
	75	9700	9250	8450	7800	7250	6850	6800	6900	7000	7050	6700	6400
420x85	40	10350	10450	10400	9800	9300	8850	7250	7300	7350	7400	7450	7500
	75	10400	10150	9250	8550	8000	7500	7300	7400	7450	7550	7300	6950
450x85	40	11000	11100	11200	10700	10150	9700	7750	7800	7850	7900	7950	8000
	75	11100	11050	10100	9350	8750	8200	7800	7850	7950	8050	7950	7600
480x85	40	11700	11800	11900	11600	11050	10550	8200	8250	8300	8350	8400	8450
	75	11750	11950	11000	10200	9550	8950	8250	8350	8400	8500	8600	8200
510x85	40	12000	12000	12000	12000	11950	11450	8700	8750	8800	8850	8900	8950
	75	12000	12000	11900	11050	10350	9750	8700	8800	8900	9000	9050	8900
540x85	40	12000	12000	12000	12000	12000	12000	9150	9200	9250	9300	9350	9400
	75	12000	12000	12000	12000	11200	10600	9200	9250	9350	9450	9550	9550
570x85	40	9450	9750	10150	11050	12000	12000	9600	9650	9700	9750	9800	9850
	75	9700	10650	12000	12000	12000	11450	9650	9750	9800	9900	10000	10100

NOTES:

1. D = member depth, B = member breadth, NS = not suitable.
2. The above table was based on a maximum ceiling mass of 20 (kg/m²).
3. Minimum bearing length = 70 mm at end supports.
4. Restraint value for slenderness calculations is 1500 mm
5. Not all sizes of SmartLam GL18 in this table are stocked in each state. Please check with your supplier before ordering

SmartFrame TOOLS

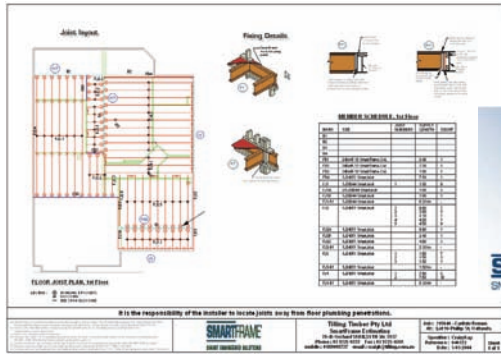

SmartFrame Software

You really do need to see our software to believe it. This state of the art *FREE* software is world leading technology. Not only does it provide the services noted previously, but you also have the benefit of being able to 'size' specific members for your project—fast. No other software package can give you all these benefits at no charge.

Quick Design -

Can't get a particular timber? Just enter the spans and you have a SmartFrame alternative. It's that easy.

Take-Off -

This is the module from which we produce our designs. Either use this yourself, or send the plans to us and we'll do it for you. The take-off is provided in A3 full colour easy to read layouts.

Bracing -

More for Designers and Engineers, this module will work out force summaries for wind bracing and more.

Connection Details -

Ever wondered how to connect an I-Joist to a steel PFC? If you have, this is the module for you. Over 30 different types of connection details all with easy to read graphics and detailed notes.

Select Bracket -

Want to be sure you've got the hardware? Visit 'select bracket' and you'll get all the info you need i.e.: size, the joists it suits and order code. Choose from straight face mount hangers, top mounts, 45° offsets, rafter to ridge hangers and even heavy duty hangers for our LVL.

Tie Down -

A powerful tool to enable users to quickly calculate the uplift forces on a structure and to assign suitable tie down solutions as contained in Chapter 9 of AS 1684

Reports -

Need a certificate report for council? Easy—just switch on your PC, bring up the job and hit the reports button. In one or two minutes, you'll have complete computer generated certifications suitable for most councils and inspectors. Of course, if they aren't satisfied,

send the job to us and our Engineer will look over it, ensure it's correct and then issue you an Engineer's Certificate.

SmartFrame Design Service

Tilling offer a comprehensive design service to builders as part of our SmartFrame builders program—at no charge. Simply give us your plans and we'll supply you with the following:



Floor Beam/Post/Lintel Layout - This is clearly show where members go, what they bear onto and how they connect within the frame, all in easy to read colour graphics.

Joist Layout - Showing the layout of joists, bearing points, where to start your layout and other site specific details such as joist hangers and rimboard/end blocking. These layouts can include location of service holes so the tradesman can adjust the joists as necessary.

Member Schedule - Our member schedule illustrates the direction of each member, size, length, count, how it bears left and right and any other information deemed to be needed.

Order Schedule - This is the take off to build the floor. Simply take a look at it to check everything is included, then fax it to your merchant for supply.

Training

Installation Training - It's not always easy for carpenters to keep up to date on new products, however to produce a well built, strong home, it's a necessity. At Tilling, we realize that education and training are lynch pins of the SmartFrame range. If you've ever used our products before, or you've just started a new chippie crew, give us a call. Given either on site, in your office or ours, installation training runs through all the details required to install our joists and LVL, including shortcuts to save time and money. Once again this service is provided at no charge to SmartFrame users. It's all part of the service to ensure you can work with confidence.



SMARTFRAME DESIGN COMPENDIUM

Design Compendium Contents

Specification Software

- Technical Support

Design Guides (pdf)

Technical Illustrations (dxf/dwg for CAD)

Fixing Details - fixing details/hangers (jpg)

Video Clips - installation/company (mpg)

Software Tutorial

Interactive



Printable



PC

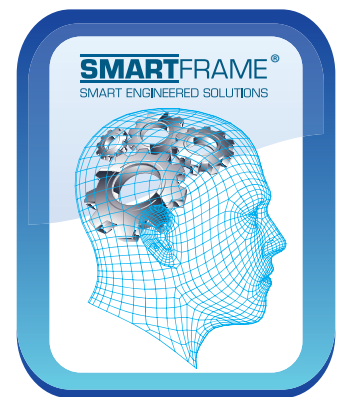

Never before has so much user friendly computer power been unleashed into the hands of building industry professionals to allow the design and detailing of engineered timber products. This software, in conjunction with the SmartFrame Design Centre and SmartFrame engineered timber products themselves, combines to form the most sophisticated structural timber option ever available to the Australian market. The SmartFrame Engineered Timber Solution represents an entirely new and revolutionary concept in the delivery of 21st century technology and service to the building industry.

Available From:

Head Office
31-45 Orchard Street,
Kilsyth, Victoria 3137

email: sales@tilling.com.au

Phone +61 3 9725 0222
Fax +61 3 9725 3045

New South Wales
109 Kurrajong Avenue,
Mt Druiitt, NSW 2770

email: nswsales@tilling.com.au

Phone +61 2 9677 2600
Fax +61 2 9677 2500

Queensland
20-24 Nealdon Drive,
Meadowbrook, QLD, 4131

email: qldsales@tilling.com.au

Phone +61 7 3440 5400
Fax +61 7 3440 5444

Western Australia
10 Cartwright Drive,
Forrestdale, WA 6112

email: wasales@tilling.com.au

Phone +61 8 9248 7643
Fax +61 8 9248 3241



www.tilling.com.au

Proudly Australian Owned

