

ENGINEERED WOOD PRODUCTS

hyJOIST® H2-S  
TERMINATOR®



## hyJOIST® Options Range Installation Guide

The natural solution for you.

 **CarterHoltHarvey**  
Woodproducts Australia



## hyJOIST Guide for Installation

hyJOIST® is a cost effective, lightweight I-Joist used in residential and commercial construction. hyJOIST is strong, light, easy to install and available in a wide range of sizes. hyJOIST gives you more options for designing economical floor joist layouts.

The hyJOIST installation requirements contained in this brochure have been successfully applied and implemented by builders for over 15 years.

By separating design considerations from installation requirements the intention is to help builders and designers sort out ‘who does what’ and minimise the potential for critical matters to ‘slip between the cracks’.

Further, there are some aspects of installation that can be regarded by designers and builders as ‘basic requirements’ to be adopted for installation together with other requirements specified in the design documentation. Requirements that fit into this category are defined and detailed under ‘Basic Installation Requirements’.

Other aspects, are categorised as ‘Installation details requiring design and specification’ because they need selection

and individual specification in the design documentation to ensure the design intent is communicated to the builder.

This guide for installation provides a variety of details specific to the use of hyJOIST floor joist systems for houses and similar buildings. Details contained in this publication have been appropriately engineer designed and/or tested to determine their suitability. In addition, many details in AS 1684 and other industry publications are equally applicable to hyJOIST as for conventional timber joisted floors – use them.

We do however, caution against any assumption that details published for other I-Joist products are suitable or sufficiently complete for use with hyJOIST.

*In all cases it is assumed that installation will be carried out in accordance with a joist layout drawing showing the location, size (section code) and maximum spacings of joists together with reference to any special requirements not included in this guide as ‘basic requirements’.*

For on-site, technical and product support, including assistance in sizing freecall

☎ 1800 808 131

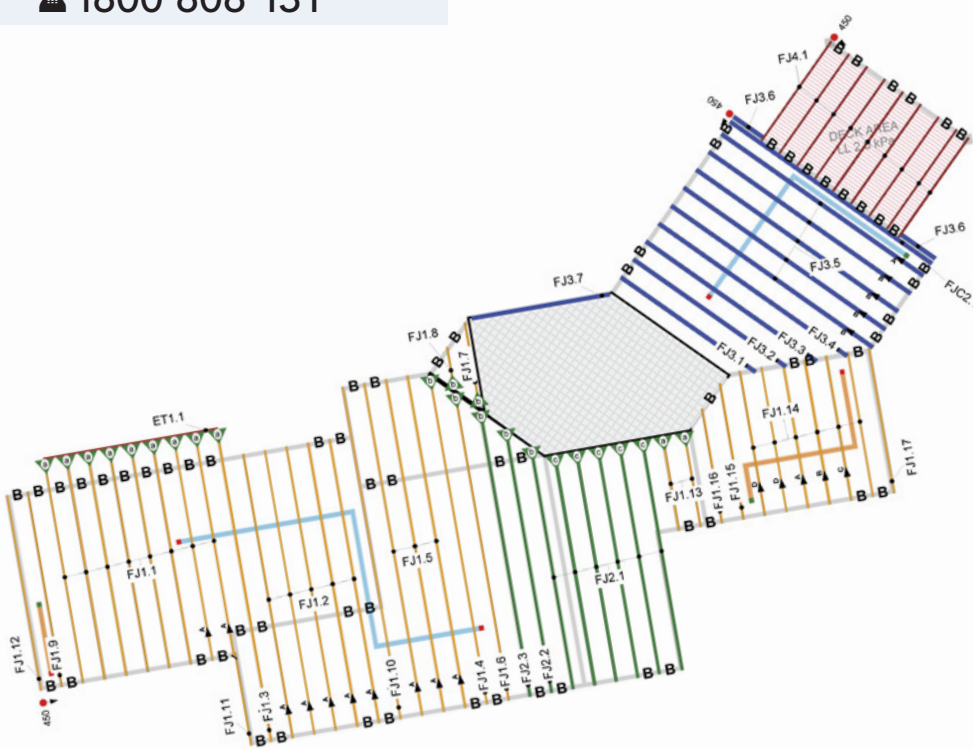

Label	Member		No/Length (m)
	Type	Size	
Quantities determined by layTOut			
FJ1.1	hyJOIST H2-S	HJ240 45	6/4.8
FJ1.1A	hyJOIST H2-S	HJ240 45	2/4.8
FJ1.2A	hyJOIST H2-S	HJ240 45	5/6.0
FJ1.3A	hyJOIST H2-S	HJ240 45	1/6.6
FJ1.4A	hyJOIST H2-S	HJ240 45	1/6.9
FJ1.5A	hyJOIST H2-S	HJ240 45	3/7.2
FJ1.6	hyJOIST H2-S	HJ240 45	1/6.6
FJ1.7	hyJOIST H2-S	HJ240 45	1/1.8
FJ1.8	hyJOIST H2-S	HJ240 45	1/1.2
FJ1.9	hyJOIST H2-S	HJ240 45	1/4.2
FJ1.10A	hyJOIST H2-S	HJ240 45	1/7.2
FJ1.11	hyJOIST H2-S	HJ240 45	1/2.1
FJ1.12	hyJOIST H2-S	HJ240 45	1/4.2
FJ1.13	hyJOIST H2-S	HJ240 45	2/2.1
FJ1.14A	hyJOIST H2-S	HJ240 45	1/3.3
FJ1.14B	hyJOIST H2-S	HJ240 45	1/3.3
FJ1.14C	hyJOIST H2-S	HJ240 45	1/3.3
FJ1.14	hyJOIST H2-S	HJ240 45	1/3.3
FJ1.14D	hyJOIST H2-S	HJ240 45	2/3.3
FJ1.15	hyJOIST H2-S	HJ240 45	1/3.0
FJ1.16	hyJOIST H2-S	HJ240 45	1/2.4
FJ1.17	hyJOIST H2-S	HJ240 45	1/3.3
FJ2.1	hyJOIST H2-S	HJ240 63	6/5.1
FJ2.2	hyJOIST H2-S	HJ240 63	1/5.7
FJ2.3	hyJOIST H2-S	HJ240 63	1/6.0
FJ3.1	hyJOIST H2-S	HJ240 90	1/3.6
FJ3.2	hyJOIST H2-S	HJ240 90	1/3.9
FJ3.3A	hyJOIST H2-S	HJ240 90	1/4.5
FJ3.4A	hyJOIST H2-S	HJ240 90	1/4.8
FJ3.5A	hyJOIST H2-S	HJ240 90	1/5.1
FJ3.5B	hyJOIST H2-S	HJ240 90	4/5.1
FJ3.6	hyJOIST H2-S	HJ240 90	2/1.2
FJ3.7	hyJOIST H2-S	HJ240 90	1/3.3*
FJ4.1	hySPAN Project H3	130 x 45	9/2.7
ET1.1	hySPAN+ H2-S	240 x 35	1/3.9

Shows typical floor joist layout as produced by layTOut® software

# Basic Installation Requirements

Installation requirements specified in this section apply as minimum requirements together with other requirements specified in the design documentation.

## Joist placement

Joists should be accurately placed at not more than the nominated maximum centre to centre spacing so as to provide the support required for flooring and load bearing walls or posts.

## Supports

Supports shall be level, dry and have at least the rigidity implied by good framing practice and/or the design criteria specified for supporting components in AS 1684. (A moisture barrier is recommended where support is directly to masonry or brickwork.)

Brackets available for use with hyJOIST are listed in Table A1 (see page 14).

## Blocking and bearing at supports (for support of gravity loads)

### General

- Bearing should be provided to the full width of the hyJOIST bottom flange.
- It is good practice to bear over the maximum available width of supports.
- Use of web stiffeners can reduce the required bearing however this needs to be specified in the design documentation.
- Continuous blocking provides support for load bearing walls directly aligned above supports. At end supports, 'rimboard' or boundary joists can be used as an alternative to continuous blocking to support a load bearing wall.

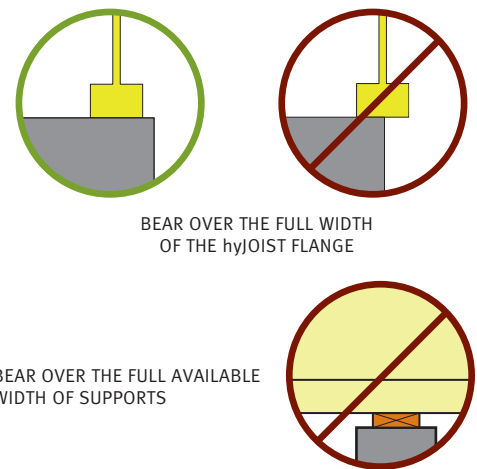

The following requirements for bearing and the support of load bearing walls can be assumed for installation in the absence of any alternative specification in the design documentation.

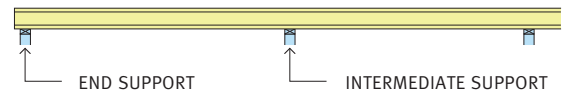

Table 1

Loads at supports	End Supports Single/continuous span		Intermediate Supports Continuous span only	
	≤ 450	600	≤ 450	600
Floor loads only	Required Bearing			
	≥ 30 mm	≥ 30 mm	≥ 45 mm	≥ 65 mm
Install intermittent blocking or equivalent – see Figure 2				
Floor loads plus compression load from a single storey load bearing wall supporting roof only	Required Bearing			
	Sheet Roof		≥ 45 mm	≥ 65 mm
	≥ 45 mm*	≥ 65 mm*		
Tile Roof				
	≥ 65 mm*	≥ 90 mm*		
Install intermittent blocking or equivalent* – see Figure 2			Install continuous hyJOIST blocking	
Floor loads plus compression load from a two storey load bearing wall supporting roof and upper floor	Required Bearing			
	≥ 65 mm	≥ 65 mm	≥ 65 mm	≥ 65 mm
Install continuous hyJOIST blocking				
Concentrated loads from jamb studs or posts	In addition to the above, install compression blocks as per Detail F18			

\* Or provide bearing as for joists supporting floor loads only and install continuous blocking, 'rimboard' or boundary joist to support roof and wall loads.

### Intermittent blocking (or equivalent) at supports

The fundamental requirement is to install joists plumb and hold them upright at supports.

The simplest and most effective way of achieving this is to install square cut hyJOIST blocking but alternative methods such as the use of ‘rimboard’, boundary joists, metal strap/brace or plywood closures are acceptable.

For installation of blocking, ‘rimboard’, boundary joist, metal strap/brace or plywood enclosures refer to Details F1, F2, F3 and F17.

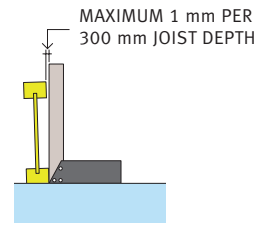
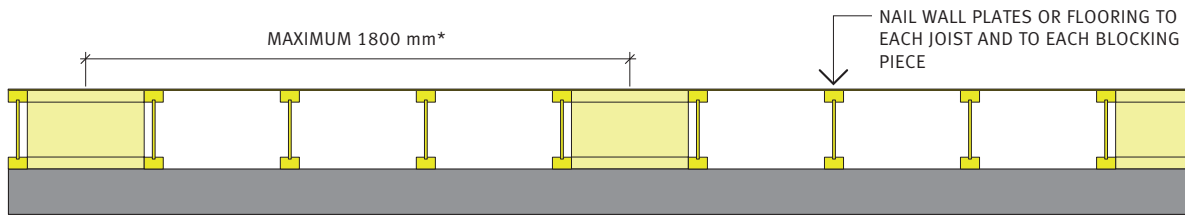

FIGURE 1



BLOCKING OR EQUIVALENT TO JOISTS AT OR NEAR THE EDGES OF THE FLOOR

BLOCK AT INTERVALS NOT EXCEEDING 1.8 m\* ALONG THE LINE OF SUPPORT

\* Blocking in pairs at 3600 mm maximum spacing is equally acceptable

FIGURE 2

### Intermediate restraint (between supports)

For best performance, the top flange of hyJOIST should be held straight between supports – (no more than 1 mm per metre of span deviation from straight)

Before loading joists and attachment of flooring

- Install blocking (or equivalent) at supports as described above, and
- between supports, install temporary battens braced back to a point of rigidity (no more than 2.5 metres apart) to hold the top flange of each joist straight between supports.
- For installation of flooring, progressively work across the floor removing battens as required.

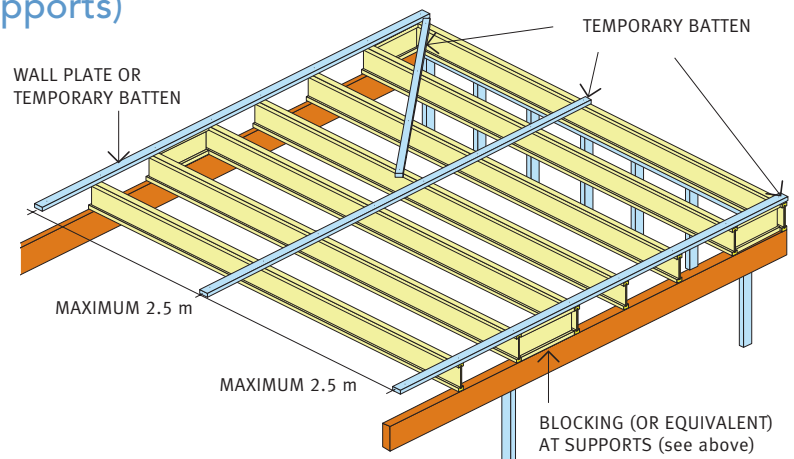

FIGURE 3

Note: Intermediate blocking is not required and can be a source of annoying nail creaks in the finished structure.

### Fixing of Flooring

Flooring may be nailed to joists and to blocking using either 2.8 mm diameter nails, hand driven or 2.5 mm diameter nails, machine driven. Alternatively, for sheet flooring self-drilling Type 17 screws may be used. Fastener lengths should not exceed the lengths given in Table 2. Nail or screw spacing should be at centres recommended for the particular flooring type. Where nail centres are less than 50 mm it is good practice to stagger their location so as to avoid the possibility of splitting. It is strongly recommended that flooring adhesive is used in conjunction with nailing.

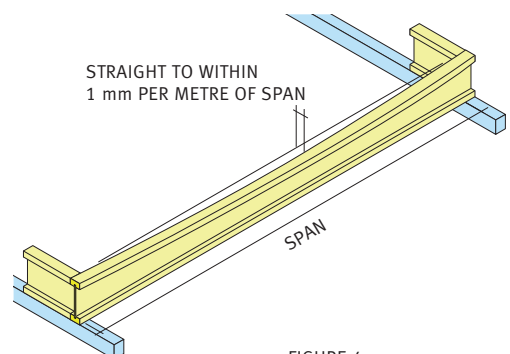

FIGURE 4

Table 2

FLOORING THICKNESS	15-20 mm	22 mm
MAXIMUM NAIL/SCREW LENGTHS	50 mm	57 mm

# Notching/Cut backs/Holes with hyJOIST

## Notches or holes in flanges

Flanges may not be notched, planed or bored except as noted below

- 1) At end supports only, one or both flanges may be notched to a maximum depth of 12 mm (per flange) as shown in Detail F7
- 2) At end supports flanges may be chamfer cut but not beyond the line of the support
- 3) Do not bore holes through flanges. Holes up to 6 mm for installation of nails or screws at supports allowed

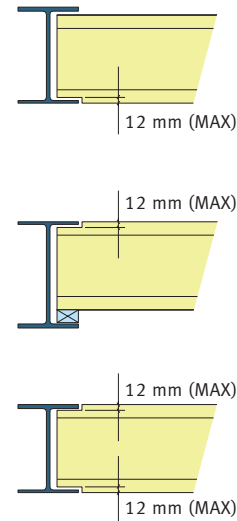
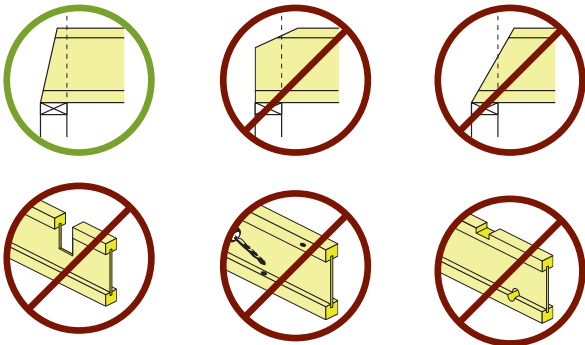

FIGURE 5

## Notches or holes in webs

- 1) At end supports webs may be notched to accommodate the flange of a steel supporting beam within the limitations specified in Detail F8.
- 2) Holes may be cut through the web of hyJOIST for the installation of service pipes and ducts but there are limitations on the placement, size and shape of holes. In general, larger holes must be located closer to midspan. Guidance on the positioning of web holes is given in Table A2 on page 15. Alternative locations may be specified in the design documentation for specific load and support cases.

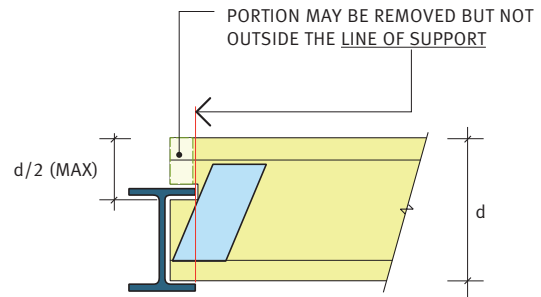

FIGURE 6

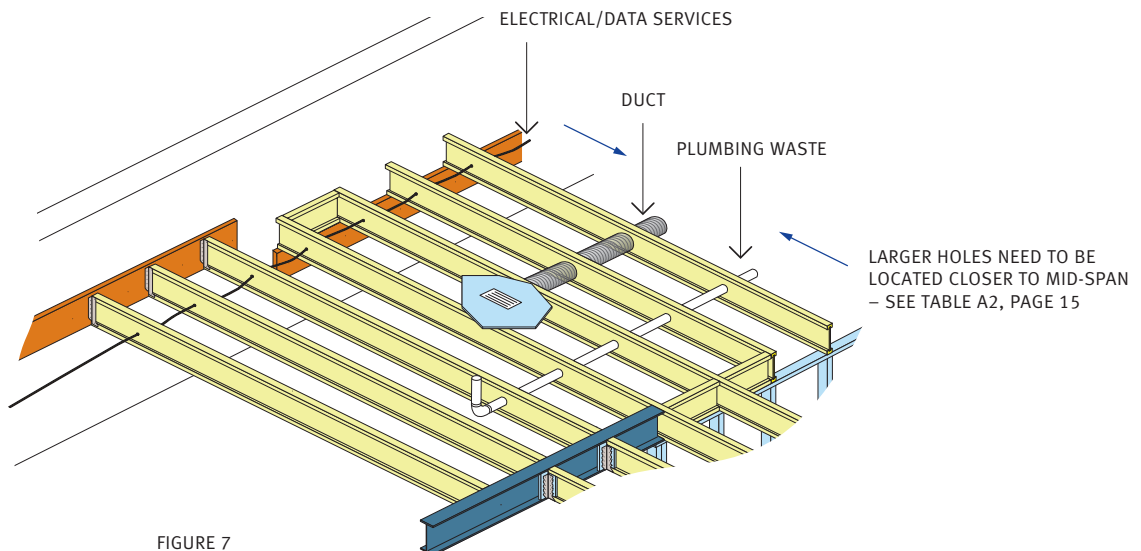

FIGURE 7

## Method for framing cantilevers supporting load bearing walls

Some or all of hyJOIST cantilevered to support a load bearing wall may require reinforcement. This requirement needs to be considered in design and specified in the design documentation. Details for reinforcement are given in Details F21 and F22.

Regardless of whether reinforcement is required or not, cantilevers with span greater than the joist depth are to be installed with continuous blocking at the cantilever support and a trimming joist (or equivalent) providing load distribution at the ends of the cantilevered joists. The use of a trimming detail helps to both stiffen the balcony and limit long term differential deflections. For installation see Detail F15.

Short cantilevers ( $L_c \leq d$ ) may need reinforcement but intermittent blocking only is needed at the cantilever support and the trimming joist need not be included – see Detail F14.

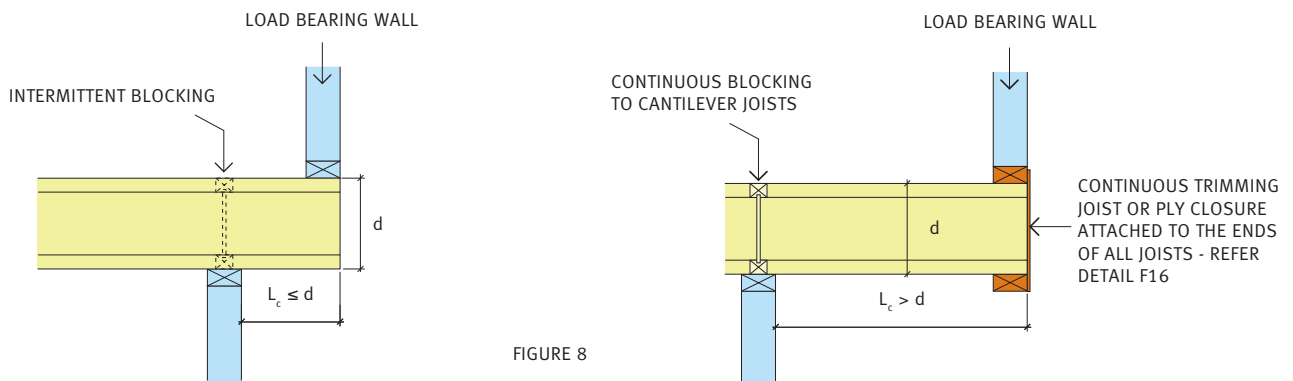

FIGURE 8

## Tie down and transfer of lateral forces through the floor

Requirements for tie down and bracing should be specified in the design documentation.

### Tie-down

In general, tie down details applicable for solid timber joists as specified in AS 1684 can also be used with hyJOIST except that bolting through the flanges of hyJOIST is not permitted.

Detail F9 shows how internal bracing walls may be tied down to a hyJOIST floor.

### Transfer of lateral forces through the floor

Lateral wind and earthquake forces determined for the upper storey must be transferred through the floor to the top plate (and the bracing system) of the lower storey. Where these forces are perpendicular to the direction of joists, intermittent blocking or the fixings to 'rimboard' or boundary joists are not likely to be adequate to transfer the full extent of the forces.

For most external walls the simplest answer is to just continue the upper storey bracing (and associated tie-down) through the floor to the top plate of the lower storey wall.

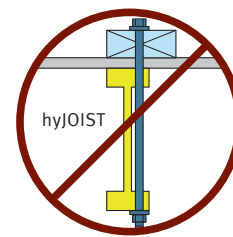

DO NOT BOLT THROUGH JOISTS

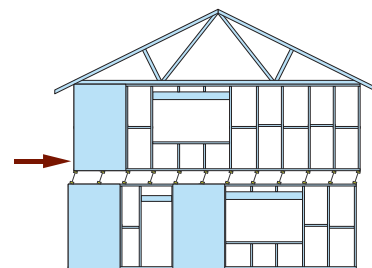
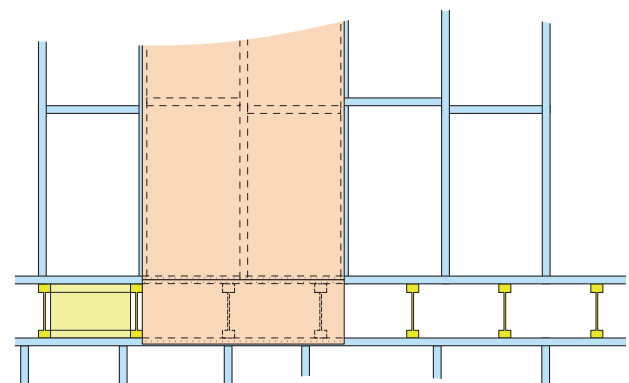

FIGURE 9



CONTINUE BRACING FOR THE UPPER STOREY THROUGH TO THE TOP PLATE OF THE LOWER STOREY WALL

FIGURE 10



Alternatively, or where continuation of bracing is not possible, such as where joists or outrigger joists are cantilevered (or for internal walls) it is recommended that sufficient blocking is provided to accommodate the nailing attachment of the upper storey wall bottom plate to the blocking and the blocking bottom flange to the top plate of the lower storey wall to match the capacity of the nailing of the upper storey bracing to the bottom wall plate. Tie-downs using metal strap or tie rods at the beginning and end of each braced portion of the wall should be carried through the floor to lower storey wall as required in AS 1684.

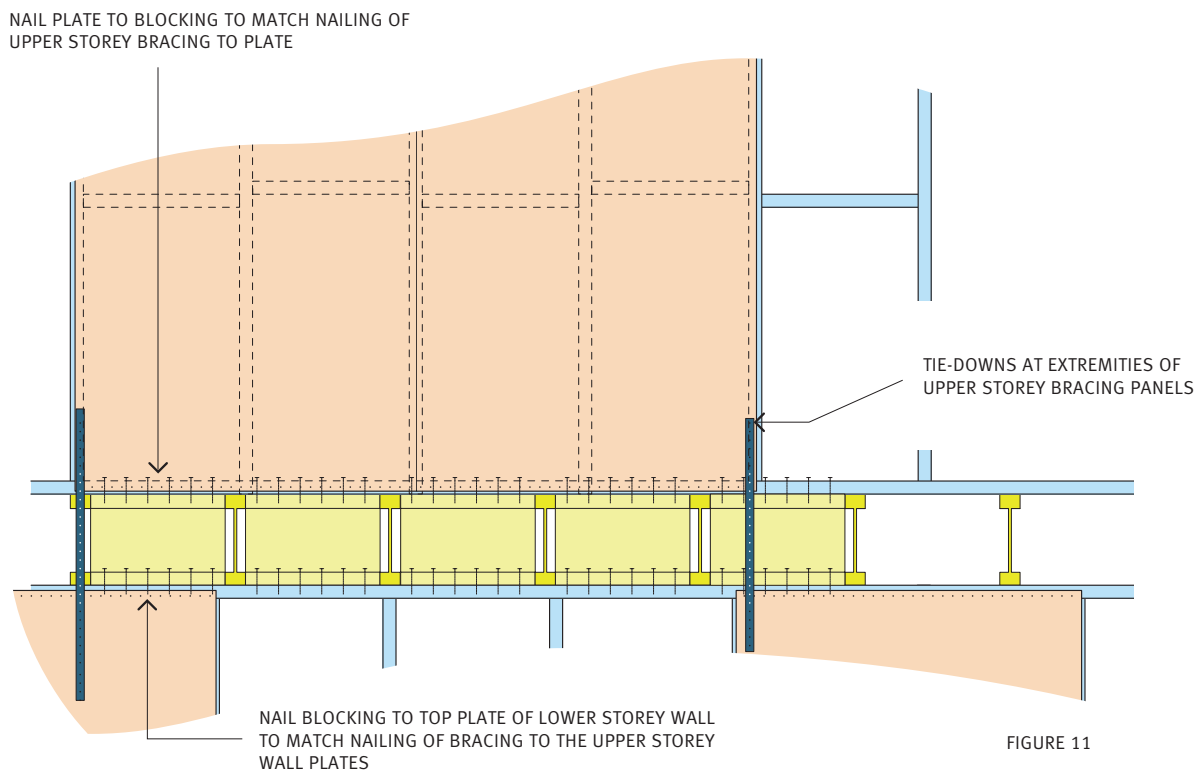

## Storage

Prior to installation hyJOIST should be stacked vertically on level bearers, at least 150 mm clear of the ground, or clear of any ponding on a floor and kept as dry as practicable.

## Product faults

Faults in manufacture do occur and faulty product will from time to time reach the market despite even the most stringent controls of the manufacturing process and quality. Please let us know if you receive faulty product – call 1800 808 131 even if you have solved the problem and a claim 'is not worth the hassle'. We want to know so that we can do better.



## Installation details requiring design & specification

The following items need design and specification in the design documentation to communicate the requirements for installation.

- Joist sizes and spacing for span, loading and flooring.
- Method of framing around openings in floors (eg stair voids).
- Method of framing balcony cantilevers.
- Reinforcement requirements for cantilevers supporting load bearing walls.
- Bearing and support requirements differing from that specified under basic requirements for installation.
- Details for tie-down and transfer of lateral forces through the floor beyond that specified in the basic requirements.
- Specification of web holes and permitted locations (not within the scope of Table A2 on page 15).

### Framing around floor openings

The size of members needed to frame around floor openings needs to be determined in design and specified in the design documentation for installation.

For convenience the depth of the trimmers and trimming joists are usually chosen to be the same as the depth of the floor joists. The ease of connecting and the greater strength and stiffness of hySPAN<sup>®</sup> relative to depth in comparison with hyJOIST makes hySPAN the ideal material for framing both the trimmers and the trimming joists.

Trimmers and the supporting trimming joists may in some cases be hyJOIST, where structurally adequate. These can be connected using top mount hangers see Table A1 on page 14 and Detail F10.

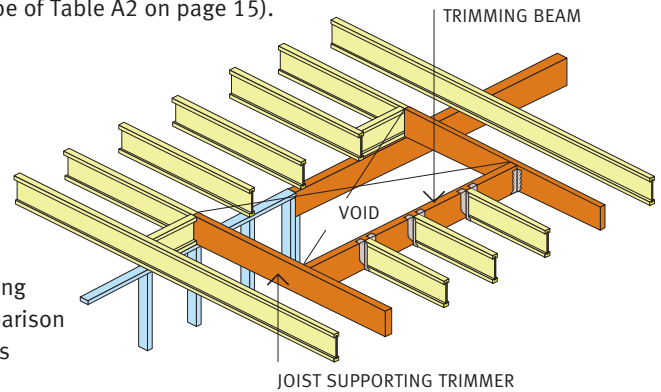

### Methods of framing balcony cantilevers

Balcony cantilevers are frequently exposed to wetting and in this circumstance there is a high risk of decay with subsequent loss of strength of the balcony structure. Although hyJOIST can be preservative treated against decay, the extent of horizontal surface available for ponding of moisture and the large surface area exposed to weathering degrade means that an I-Joist section is comparatively at a higher risk than an equivalent solid rectangular section. For this reason, hyJOIST is not recommended for external or weather exposed balcony cantilevers regardless of whether it has been preservative treated or not.

Instead, the use of outrigger framing as described below is recommended.

### Balcony cantilevers using outriggers

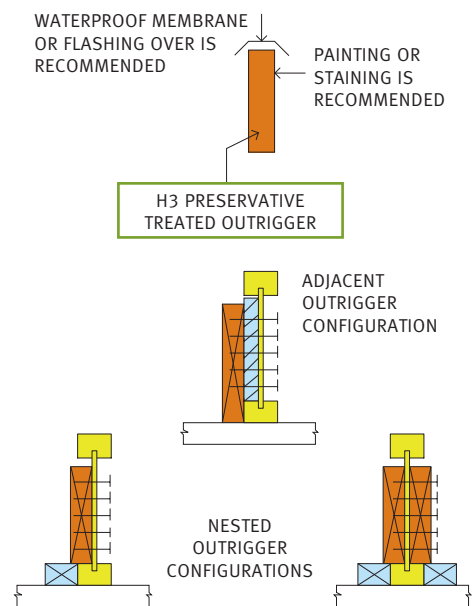
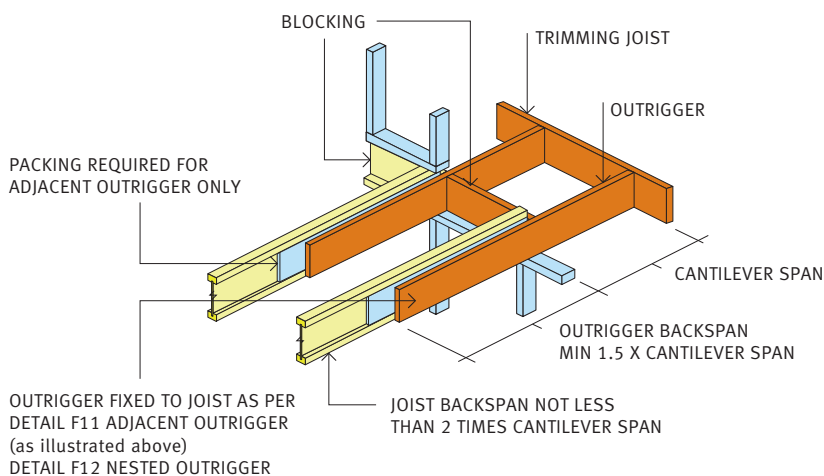

Design should include specification of either the 'adjacent' or 'nested' outrigger detail and the specification of the outrigger material. Outrigger length and quantities can be determined and the installation performed in accordance with the specified detail.

For weather protected or internal balcony cantilevers Detail F13 may be used.



End restraint  
- blocking with hyJOIST

WALL PLATE/FLOORING OR TEMPORARY BATTEN, NAILED TO hyJOIST JOISTS. NAIL THROUGH FLOORING OR WALL PLATE INTO BLOCKING FOR PERMANENT INSTALLATION.

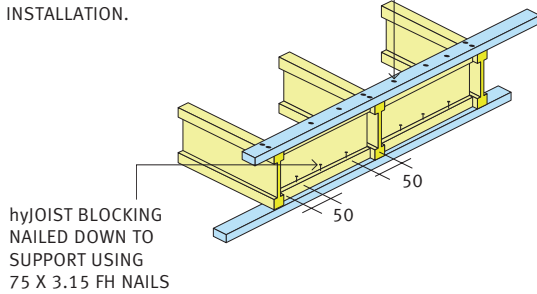

DETAIL F1

End restraint  
- using steel strap or bracing

WALL PLATE, FLOORING OR TEMPORARY BATTEN, NAILED TO HYJOIST

JOIST BRACED WITH SPEEDBRACE OR SPEED STRAP

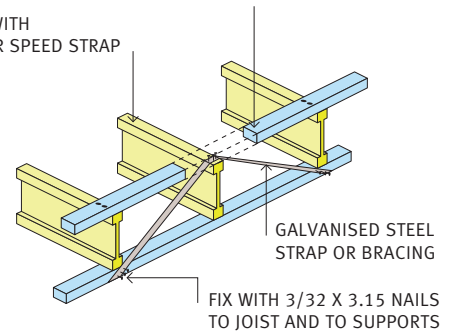

DETAIL F2

End restraint  
- using ply or hardboard bracing

WALL PLATE OR BATTEN

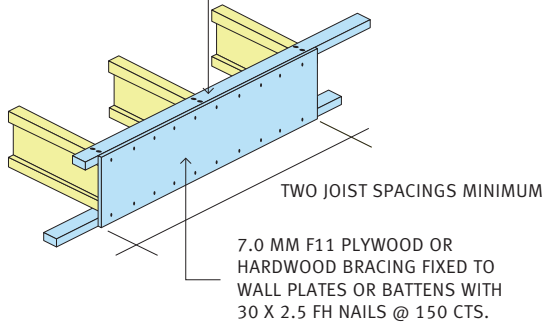

DETAIL F3

Fixing hyJOIST to steel beams  
- using face mount hangers

PACKERS  
70 X 35 OR 70 X 45  
SOFTWOOD PACKERS  
SHOT FASTENED  
TO STEEL WEB

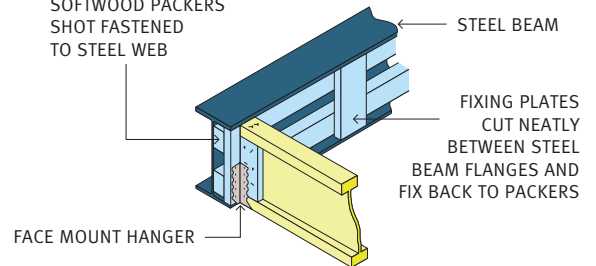

DETAIL F4

Nailing down to supports

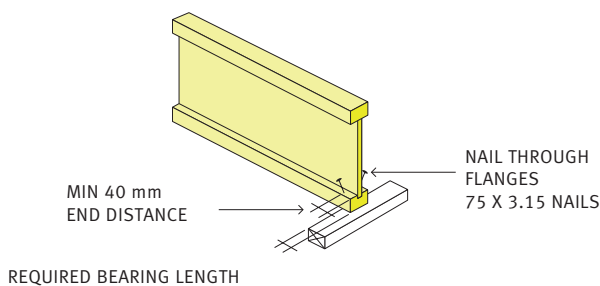

DETAIL F5

Installation of web stiffeners

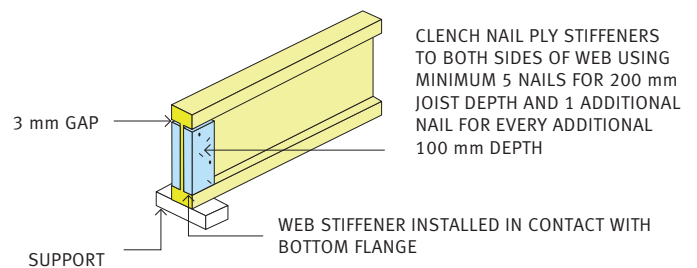

STIFFENER/PACKER THICKNESSES*	NAIL LENGTH
45 mm FLANGE	50 mm
63 mm FLANGE	75 mm
90 mm FLANGE	100 mm

\* Plywood of appropriate thickness is available as an accessory product

DETAIL F6

### Notching of flanges at end supports

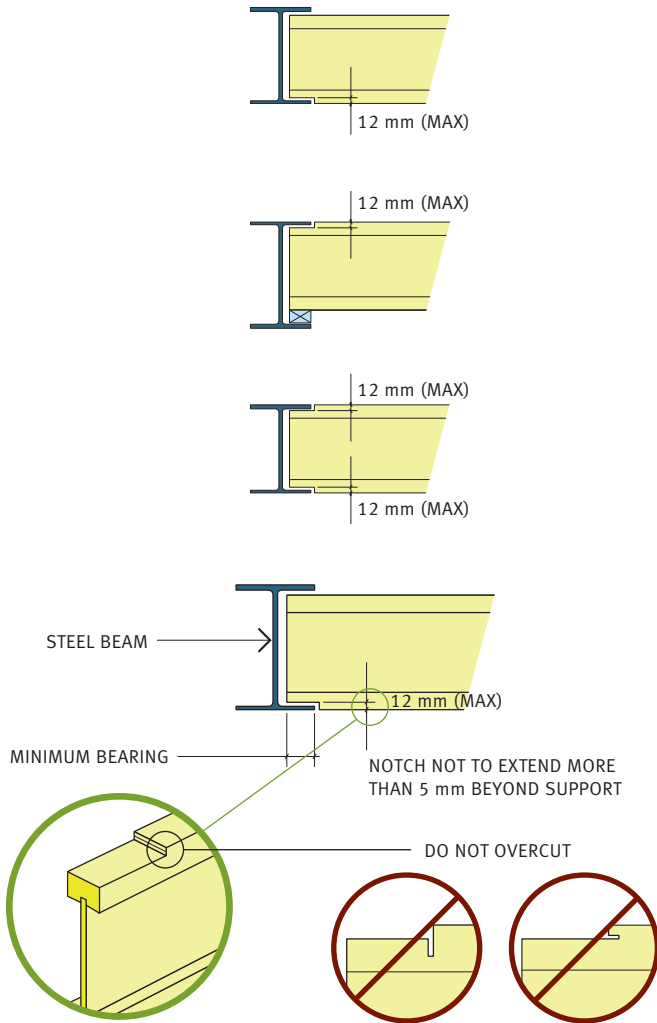

DETAIL F7

### Notching of webs for steel beam flange

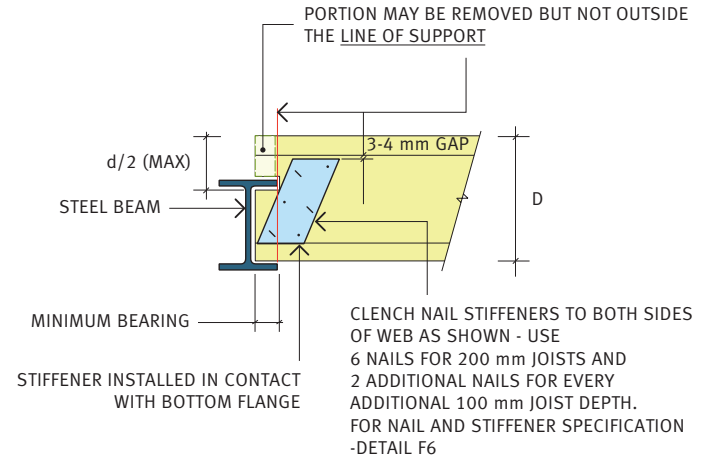

DETAIL F8

### Tie-down to internal bracing wall

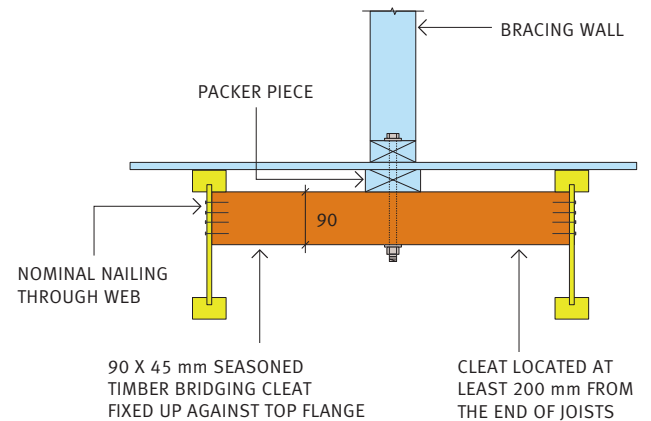

DETAIL F9

### hyJOIST / hyJOIST connection

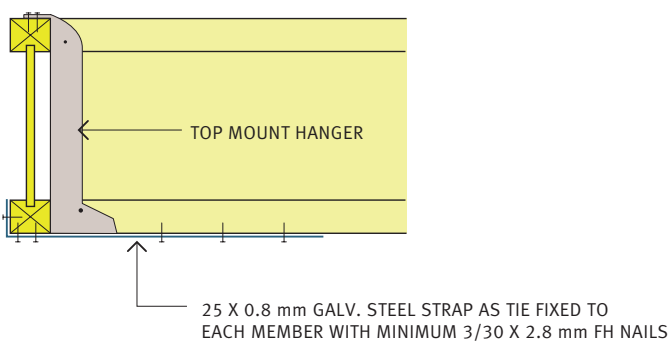

DETAIL F10

### Adjacent outrigger

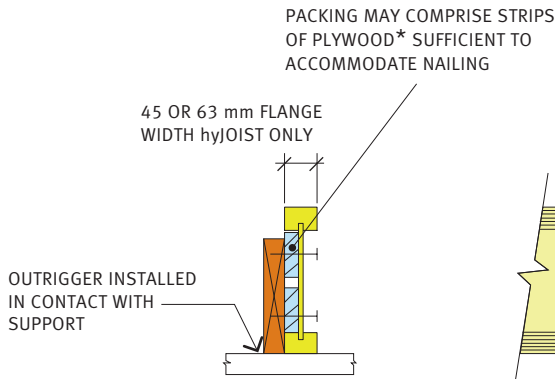

\* Plywood strips of suitable thickness available as accessory product

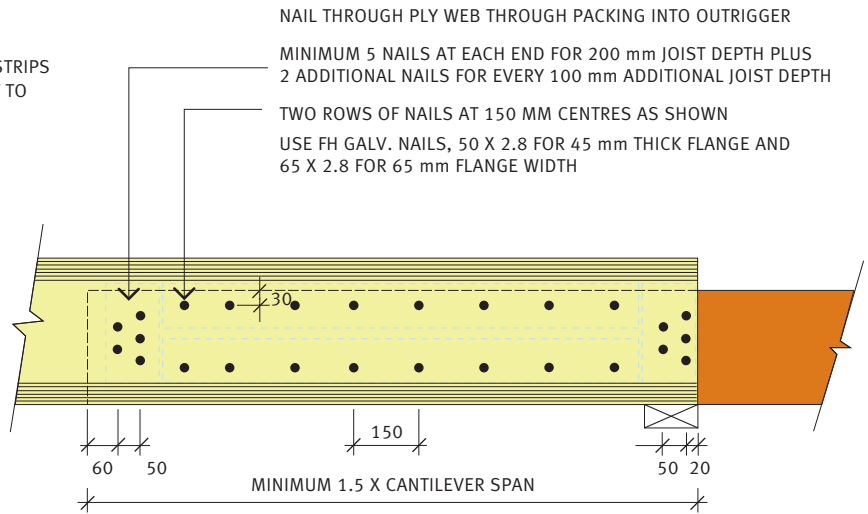

DETAIL F11

### Nested outrigger installation

OUTRIGGER INSTALLED IN CONTACT WITH hyJOIST SUPPORT AND TIMBER BLOCK

TIMBER BLOCK OF THICKNESS TO MATCH hyJOIST FLANGE THICKNESS

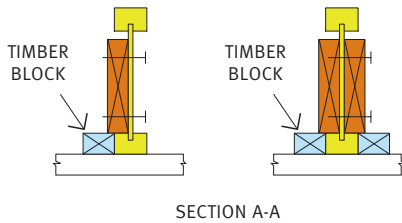

DOUBLE OUTRIGGER NAILING TO MATCH AS SHOWN FOR SINGLE OUTRIGGER

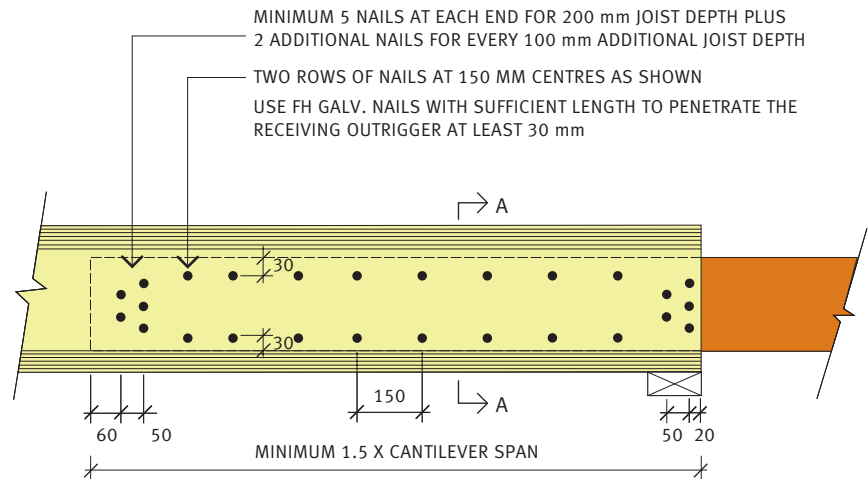

DETAIL F12

### hyJOIST cantilever for internal or weather proofed balcony applications

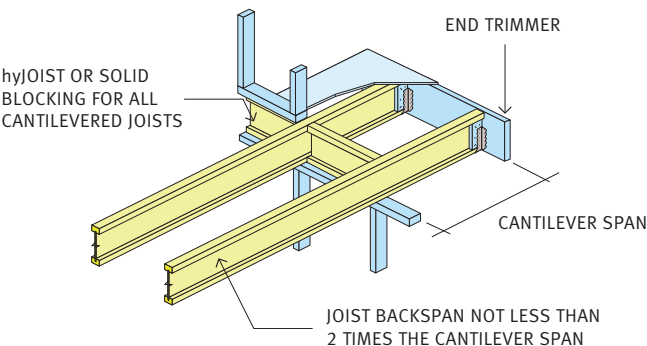

FOR EXTERNAL USE, hyJOIST FLOOR JOISTS MUST BE PROTECTED FROM BECOMING WET BY A FULLY WATERPROOF DECK

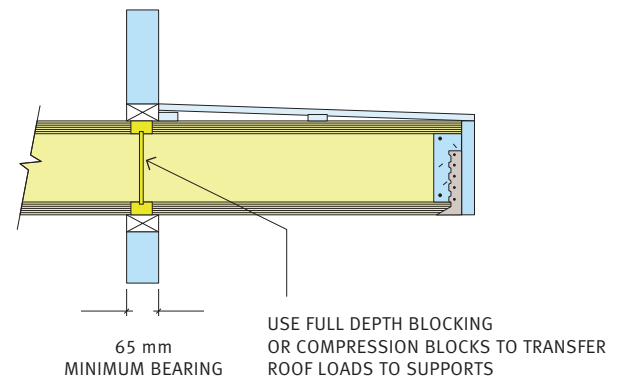

DETAIL F13

Short cantilever supporting load bearing wall

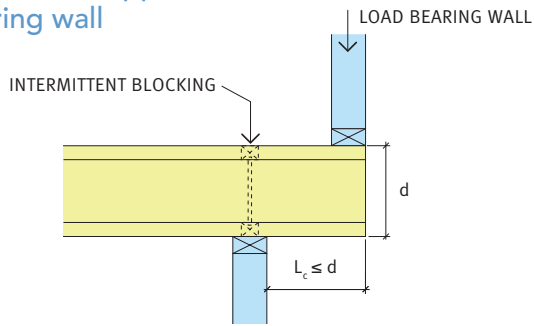

WHERE SPECIFIED  
INSTALL TYPE 1 REINFORCEMENT IN ACCORDANCE WITH DETAIL F21  
INSTALL TYPE 2 REINFORCEMENT IN ACCORDANCE WITH DETAIL F22

DETAIL F14

Cantilever supporting load bearing wall

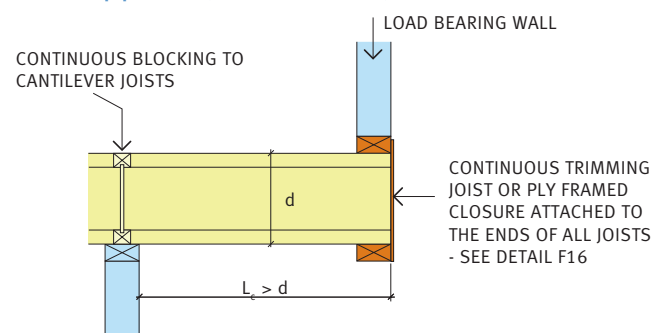

WHERE SPECIFIED  
INSTALL TYPE 1 REINFORCEMENT IN ACCORDANCE WITH DETAIL F21  
INSTALL TYPE 2 REINFORCEMENT IN ACCORDANCE WITH DETAIL F22

DETAIL F15

Cantilevers supporting load bearing walls  
- installation of end trimmer

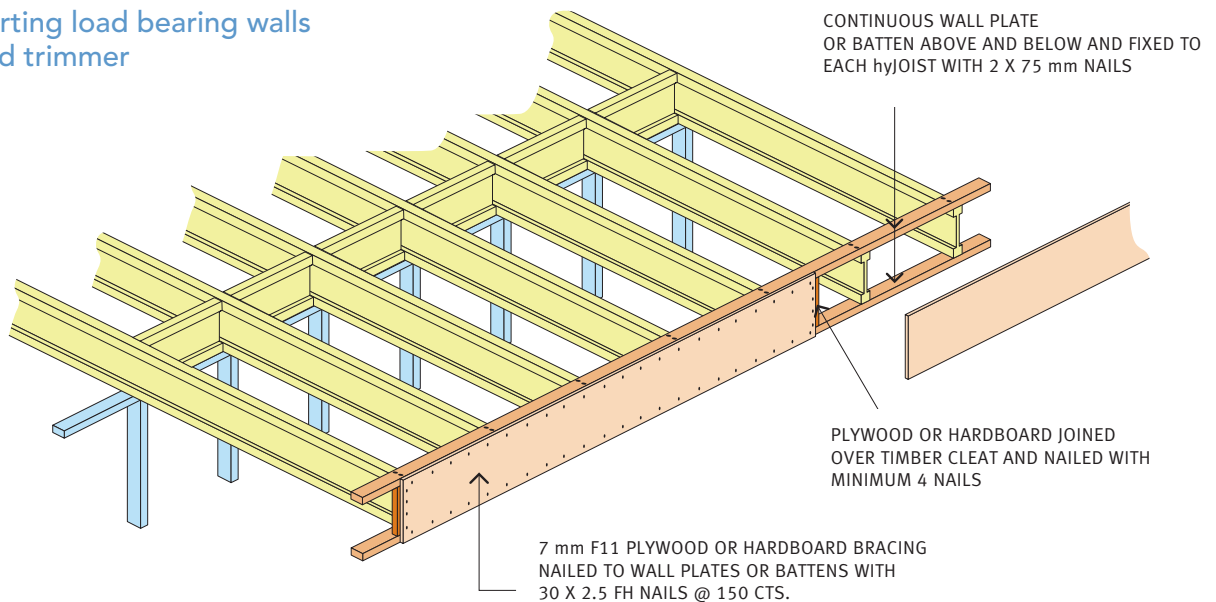

DETAIL F16

End restraint  
- using 'rimboard' or boundary joist

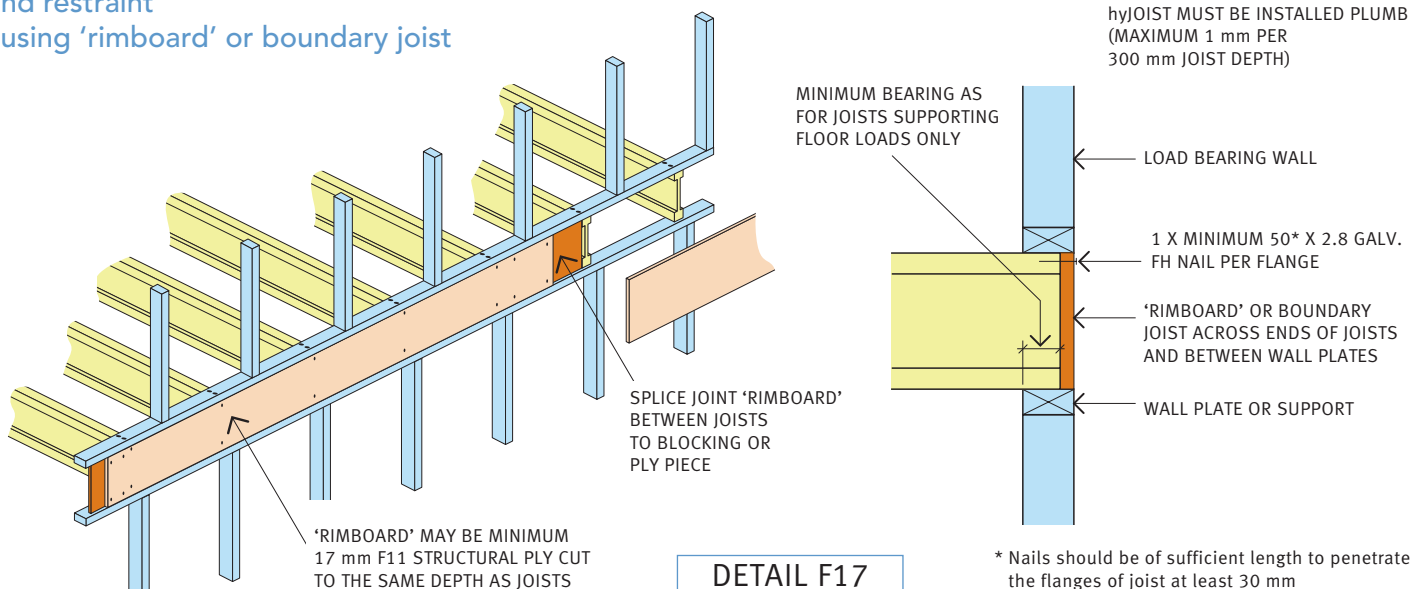

DETAIL F17

\* Nails should be of sufficient length to penetrate the flanges of joist at least 30 mm

Installation of compression blocks

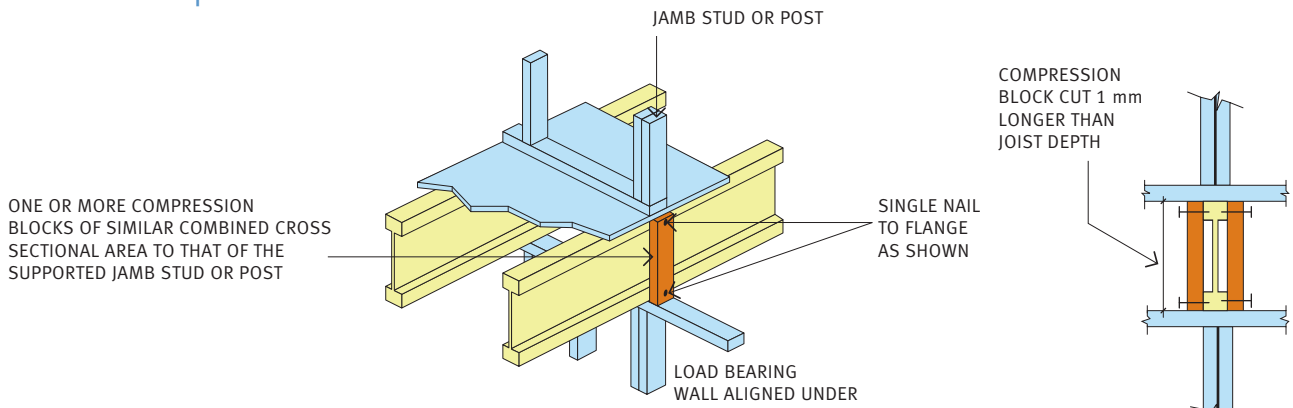

DETAIL F18

Cantilever supporting load bearing walls - Type 1 reinforcement

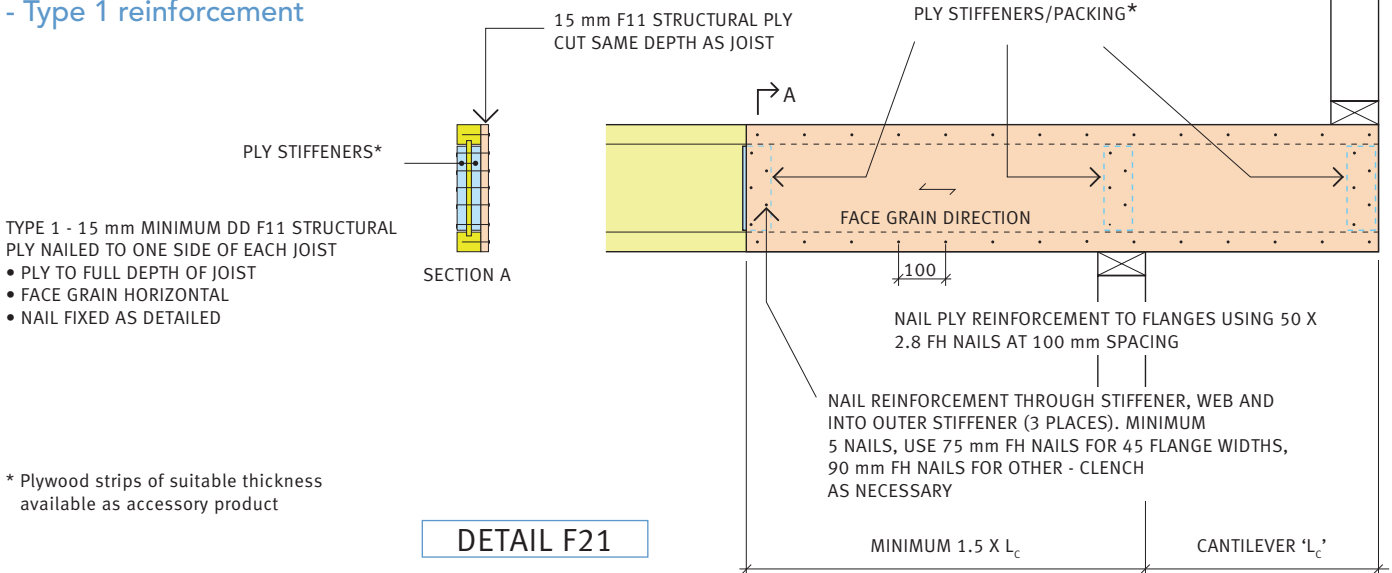

- TYPE 1 - 15 mm MINIMUM DD F11 STRUCTURAL PLY NAILED TO ONE SIDE OF EACH JOIST
- PLY TO FULL DEPTH OF JOIST
  - FACE GRAIN HORIZONTAL
  - NAIL FIXED AS DETAILED

\* Plywood strips of suitable thickness available as accessory product

DETAIL F21

Cantilever supporting load bearing walls - Type 2 reinforcement

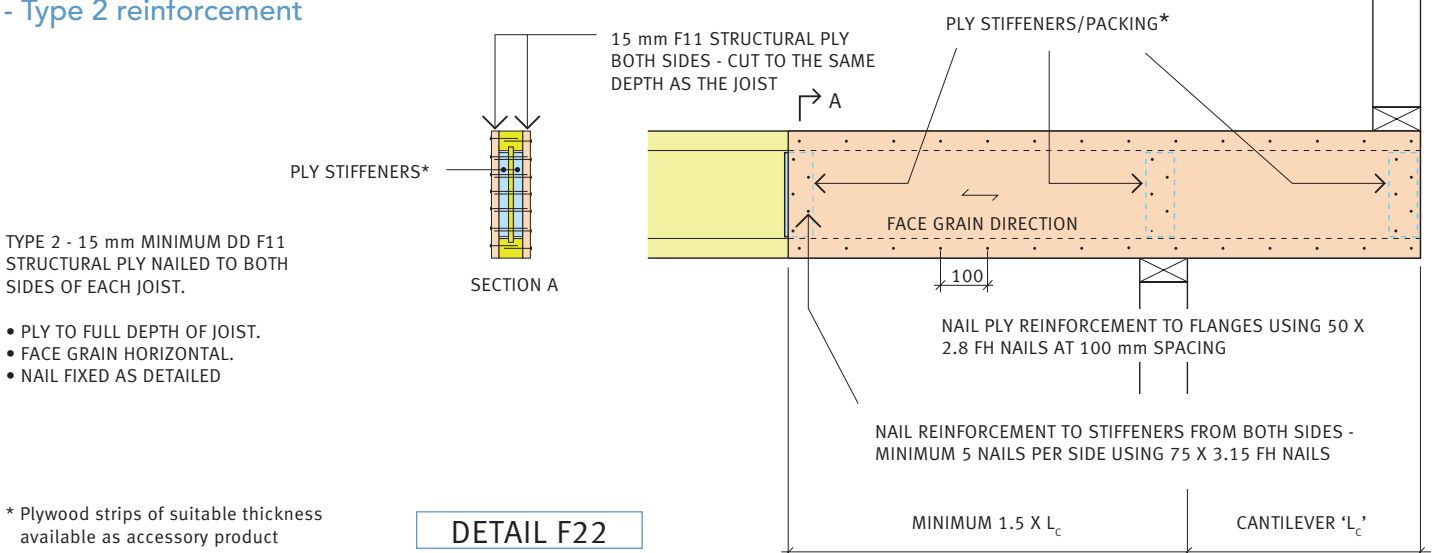

TYPE 2 - 15 mm MINIMUM DD F11 STRUCTURAL PLY NAILED TO BOTH SIDES OF EACH JOIST.

- PLY TO FULL DEPTH OF JOIST.
- FACE GRAIN HORIZONTAL.
- NAIL FIXED AS DETAILED

\* Plywood strips of suitable thickness available as accessory product

DETAIL F22

## Appendix

## Joist hangers and brackets

Table A1 joist hangers for hyJOIST

hyJOIST SECTION CODE	MANUFACTURER OR DISTRIBUTOR	FACE MOUNT HANGERS				TOP MOUNT HANGERS
		FULL DEPTH		PARTIAL DEPTH		
		HANGER CODE	MINIMUM N <sup>o</sup> OF NAILS TO BEARER	HANGER CODE	MINIMUM N <sup>o</sup> OF NAILS TO BEARER	
HJ200 45	Pryda	LF190/50	6	FB50180	8	LT200/50
	Mitek	IBHF20050	6			IBHT20050
HJ240 45	Pryda	LF235/50	6	FB50220	8	LT240/50
	Mitek	IBHF24050	6			IBHT24050
HJ240 63	Pryda	LF235/65	8	FB65170	10	LT240/65
	Mitek	IBHF24065	8			IBHT24065
HJ240 90	Pryda	LF235/90	8	FB90200	10	LT240/90
	Mitek	IBHF24090	8			IBHT24090
HJ300 45	Pryda	LF297/50	8	FB50220	10	LT300/47
	Mitek	IBHF30050	8			IBHT30050
HJ300 63	Pryda	LF290/65	8	FB65170	10	LT302/65
	Mitek	IBHF30065	8			IBHT30065
HJ300 90	Pryda	LF290/90	8	FB90200	12	LT300/90
	Mitek	IBHF30090	8			IBHT30090
HJ360 63	Pryda	LF340/65	8	FB65170	12	LT360/65
	Mitek	IBHF36065	8			IBHT36065
HJ360 90	Pryda	LF350/90	10	FB90200	12	LT356/90
	Mitek	IBHF36090	10			IBHT36090
HJ400 90	Pryda			LF350/90	14	LT400/90
	Mitek	IBHF40090	10			IBHT40090

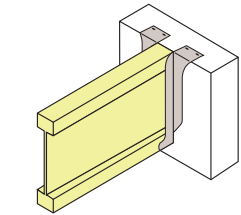

TOP MOUNT HANGER

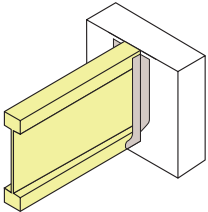

FULL DEPTH FACE MOUNT HANGER

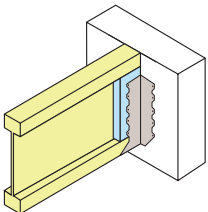

PARTIAL DEPTH FACE MOUNT HANGER WITH PACKING TO WEB

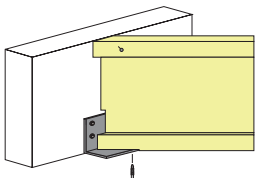

SKEW ANGLE BRACKET AVAILABLE FROM PRYDA – PRYDA CODE: LV5IA

1. Nailing specified is for brackets face fixed to hySPAN or JD4 (or better) timber bearer or wale plate.
2. Brackets to be installed strictly in accordance with bracket manufacturers' recommendations. Note, nails for FB hangers are 35 x 3.15 flat head type; for all other hangers 35 x 3.75 flat head nails are specified.
3. Nailing specification applies for joists used for floors in houses with floor mass not exceeding 100 kg/m<sup>2</sup>.

## Web holes for hyJOIST

Holes may be cut through the web of hyJOIST provided they are located within the central part of the span as specified below.

The following Tables specify allowable hole locations for some sizes of circular and rectangular holes. These limitations should be assumed to apply in the absence of alternative specification in the design documentation. (For particular load and support conditions or other hole sizes and shapes alternative allowable hole positions may be specified using designIT software.)

### Circular holes

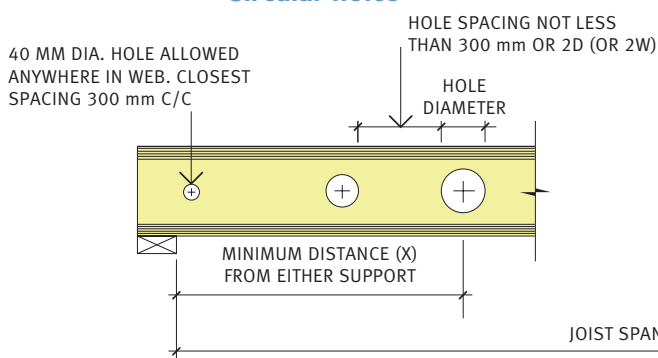

### Rectangular holes

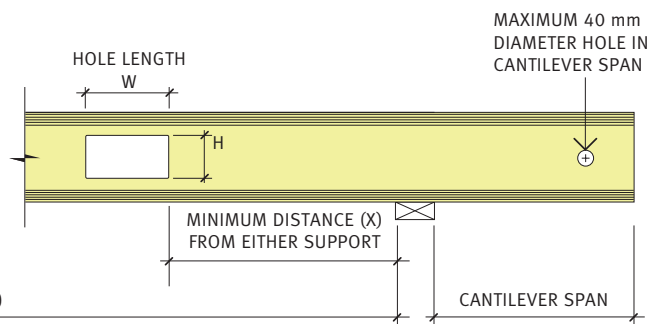

Table A2 web holes

Circular holes

hyJOIST SECTION CODE	MAXIMUM HOLE DIAMETER (mm)	MINIMUM DISTANCE FROM SUPPORT 'X'	HOLE DIAMETER (mm)			
			ø80	ø110	ø125	ø150
			CIRCULAR HOLES – MINIMUM DISTANCE 'X' FROM SUPPORT – (m)			
HJ200 45	ø118	0.34L <sup>1</sup>	0.16L	0.28L	N/A	N/A
HJ240 45	ø158	0.38L	0.12L	0.21L	0.26L	0.33L
HJ240 63			0.12L	0.21L	0.26L	0.33L
HJ240 90			0.12L	0.21L	0.26L	0.33L
HJ300 45	ø218	0.41L	0.10L*	0.15L	0.18L	0.24L
HJ300 63			0.10L*	0.15L	0.18L	0.24L
HJ300 90			0.10L*	0.10L*	0.14L	0.20L
HJ360 63	ø278	0.42L	0.3 m*	0.08L*	0.11L	0.16L
HJ360 90		0.40L	0.3 m*	0.3 m*	0.3 m*	0.05L*
HJ400 90	ø318	0.40L	0.3 m*	0.3 m*	0.3 m*	0.08L*

\* Minimum distance from any support is 0.3 metres

1. Example, if the actual span 'L' = 4.0 m then minimum distance 'X' from hole to the support (see diagram) is 0.34 x 4 = 1.36 m

Rectangular holes

hyJOIST SECTION CODE	HOLE SIZE		PERMITTED LOCATIONS FOR RECTANGULAR HOLES								
	HEIGHT (mm)	LENGTH (mm)	L	Actual Span 'L' in metres							
			X	Minimum distance from the side of the hole to any support – (m)							
HJ200 45	118	230	L	≤ 3.8	4.0	4.2	4.4	4.5			
			X	0.34L	1.38	1.59	1.80	1.90			
HJ240 45	158	310	L	≤ 3.5	3.6	3.8	4.0	4.2	4.4	4.6	4.7
			X	0.38L	1.36	1.50	1.65	1.80	1.95	2.10	2.18
HJ240 63	158	310	L	≤ 3.5	5.5						
			X	0.38L	2.13						
HJ240 90	158	310	L	≤ 5.8	6.0	6.1					
			X	0.38L	2.36	2.45					
HJ300 45	218	400	L	≤ 3.6	3.8	4.0	4.2	4.4	4.6		
			X	0.41L	1.58	1.71	1.84	1.97	2.10		
HJ300 63	218	400	L	≤ 5.2	5.4	5.6	5.8	6.0	6.2	6.3	
			X	0.41L	2.25	2.39	2.54	2.69	2.83	2.91	
HJ300 90	218	400	L	≤ 6.4	6.6	6.8	7.0				
			X	0.40L	2.73	2.88	3.04				
HJ360 63	278	500	L	≤ 5.4	5.6	5.8	6.0	6.2	6.4	6.6	6.8
			X	0.42L	2.37	2.49	2.62	2.75	2.88	3.02	3.15
HJ360 90	278	500	L	≤ 7.2	7.4	7.6	7.7				
			X	0.40L	2.97	3.10	3.17				
HJ400 90	318	600	L	≤ 8.0							
			X	0.40L							

Interpolate to obtain values of 'X' for spans intermediate between the values given

Notes:

1. Spacing between holes to be not less than 300 mm or twice the width (or twice the diameter) of the larger hole.
2. Not more than three holes with width or diameter greater than 80 mm in any span.
3. For cantilever spans, holes greater than 40 mm diameter are not permitted.
4. Web hole data applies for hyJOIST used for floors in houses.

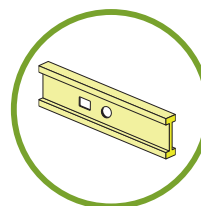

DO CUT IN WEB AREA AS SPECIFIED

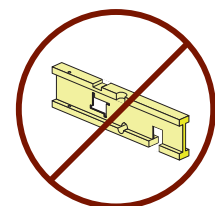

DO NOT CUT, NOTCH OR BORE THROUGH FLANGE

## Save time and money with better support



### Fast technical support ☎️ 1800 808 131

For quick, clear product answers, our technical support phone line – 1800 808 131 – links you to our expanded, engineering support team. Our experienced support team can assist with enquiries ranging from beam sizing to installation advice. It's fast, easy and it's free.



### Powerful building design software

designIT® software is a powerful tool for all building practitioners to quickly and simply design more economical floor, wall and roof members. designIT has been recently upgraded and the enhancements include:

- Beam sizing grouped in floor, wall and roofing applications
- Stud design, including design of notched studs along with top and bottom wall plates
- Reaction and serviceability reports - detailed reports for every member
- Increased design options for a range of building materials

Quick and simple to use yet deceptively powerful software.

Save time and money - download designIT FREE at [www.chhsoftware.com/designIT](http://www.chhsoftware.com/designIT)



FREE



designIT site

### Design it now on site

designIT site is a slim version of designIT for houses customised for use on site. designIT site allows building practitioners to quickly and simply:

- Calculate holes in hyJOIST for services
- Find common fixing details
- Specify common rafter overhangs
- Check bearer, joist and rafter design

Save time on site - download designIT site FREE.

For more visit [www.chhsoftware.com/apps](http://www.chhsoftware.com/apps)

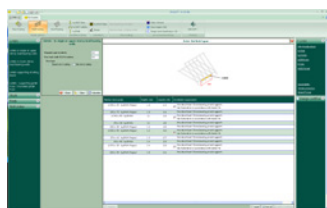
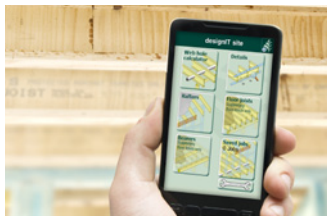

Lintel Screen

### Floor beam layout and take-off service

Distributors of hyJOIST can provide a floor beam design, layout and material take-off service using Carter Holt Harvey's proprietary software layITout. Simply contact your supplier for further details regarding this service.

Available from:



#### VICTORIA

58 Whiteside Road  
Clayton South VIC 3169

Ph: 03 8540 0500

Fx: 03 8540 0599

[vicsales@dindas.com.au](mailto:vicsales@dindas.com.au)

#### NEW SOUTH WALES

138 Dunheved Circuit  
St. Mary's NSW 2760

Ph: 02 9673 8000

Fx: 02 9673 8099

[nswsales@dindas.com.au](mailto:nswsales@dindas.com.au)

#### QUEENSLAND

433 Wondall Road  
Tingalpa QLD 4173

Ph: 07 3249 9888

Fx: 07 3390 8382

[qldsales@dindas.com.au](mailto:qldsales@dindas.com.au)

Technical Support

☎️ 1800 808 131

[chhwoodproducts.com.au/hyjoist](http://chhwoodproducts.com.au/hyjoist)